

# TSUBAKI Electrical Control Devices



# Tsubaki electrical control devices boost visualization and equipment management in factories

Rapidly advancing IoT is raising productivity and quality in factories.

Tsubaki plays a key role here, with electrical control devices that watch over factories by providing visualization of operational circumstances and detection of overload.

## Shock Relay

These current-monitoring control devices quickly detect overcurrent during motor overload and thus prevent equipment from damage. Their applications include lifting/lowering devices and conveyors.

Features

- Quickly detects overcurrent
- Easy to install onto existing equipment
- Sends emergency signal only when problems detected



SC Series



ED Series



SB Series



150 Series



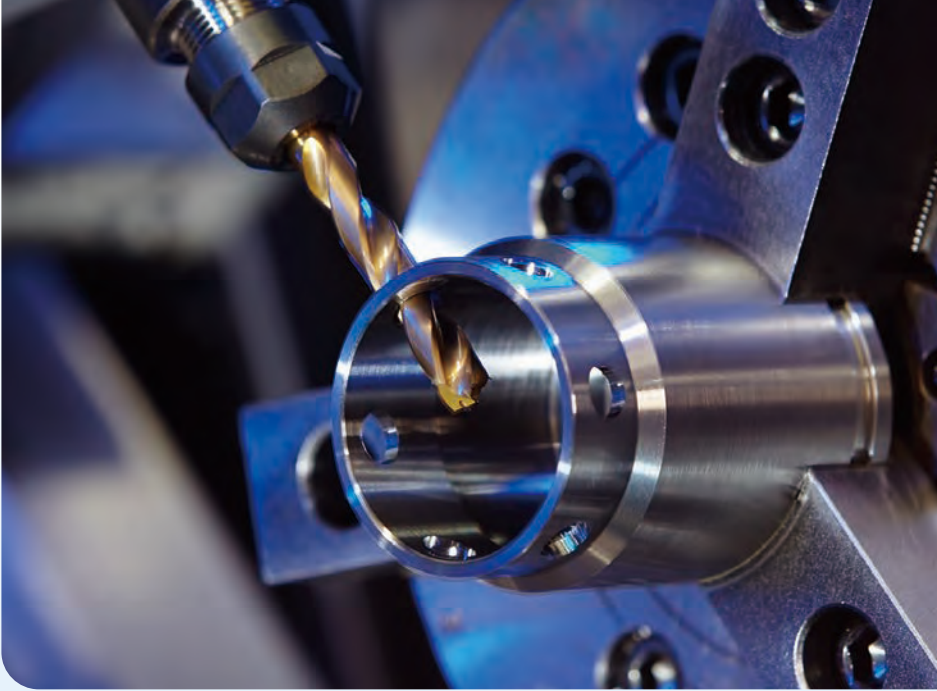

## Shock Monitor

These electricity-monitoring control devices detect minimal load variations by monitoring motor input power. They can be used on machine tools to shorten processing times and detect broken drills.

### Features

- Power detection to monitor minimal variations in load
- Wide frequency range (5 to 120 Hz)
- Quick response
- Records load conditions



Basic type



Economy type (H1)



Contact detection type (M1)



Tool breakage detection type (M3)

## Applications ideal for protecting

### Hoisting system



Shock Relay  
ED Series

Detects overweight

#### Features

- Load value can be precisely set while verifying motor current on the digital display during operation
- Economical



### Multiple conveyors



Shock Relay  
SC Series

Online remote monitoring

#### Features

- Loads on multiple conveyors can be monitored remotely with a connected PC
- Parameter values can also be changed remotely



### Dishwasher



Shock Relay  
SB Series

Stops equipment when spoons or other utensils get jammed in the machine

#### Features

- Compact
- Economical
- Can be installed inside the control box

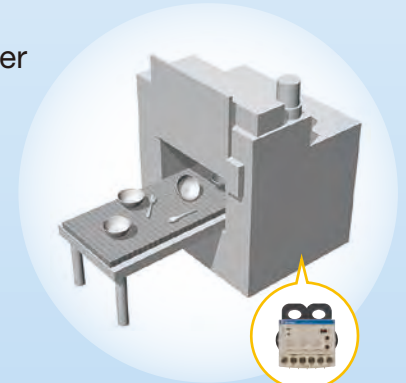

### Power Sensors

Realize preventive device maintenance and automation by detecting minute overload variations in things like grindstone-workpiece contact, tool wear, and crusher automatic operation.

### Grinding machine



Shock Monitor  
TSM4000M1

Through contact detection of grindstone-workpiece, the grinding cycle can be reduced and grindstone processing starting points can be found

#### Features

- Can offset the load factor at no-load operation before contact with the workpiece, allowing detection of only tiny contact loads



# machine/equipment from overload

## Shredder



Shock Relay  
SB Series

Stops the shredder when the load becomes heavy

### Features

- Automatic reset suitable for frequent stops
- Compact
- Economical



## Multi-spindle drilling machine



Shock Monitor  
TSM4000

Overload protection and tool breakage detection

### Features

- During machining, detects overload and tool breakage with high precision
- Selectable value for each tool (8 types)



## Water treatment equipment



Shock Monitor  
TSM4000H2

Sewage collector overload protection

### Features

- Thanks to the load-following function, the set value can be followed and abnormal load can be detected precisely even if there is a small efficiency change in the high-gear-ratio reducer

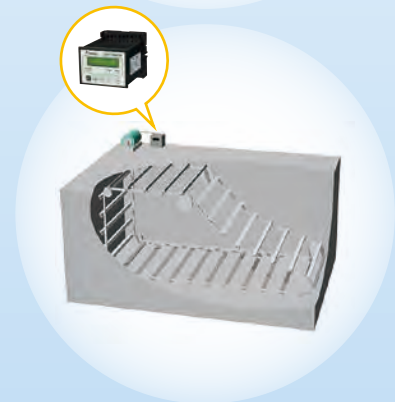

## Lathe

Chip wear detection



Shock Monitor  
TSM4000M2

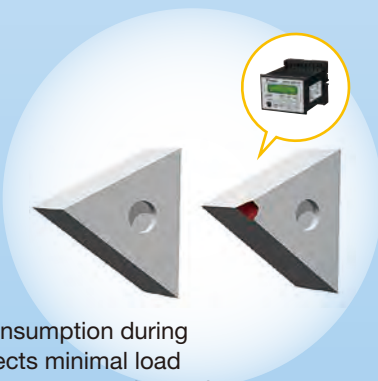

### Features

- Integrates power consumption during processing and detects minimal load variations due to wear, so users know the appropriate time to change the chips

## Drilling machine

Tool breakage detection during continuous processing



Shock Monitor  
TSM4000M3

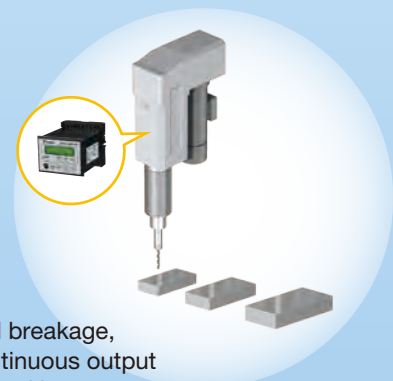

### Features

- Quickly detects tool breakage, thus preventing continuous output of defective processed items





TT-net is the comprehensive technology site for Tsubaki products.

From here users can download information on products and sizing, as well as drawings and catalogs.

TT-net URL ▶▶▶ <https://tt-net.tsubakimoto.co.jp>

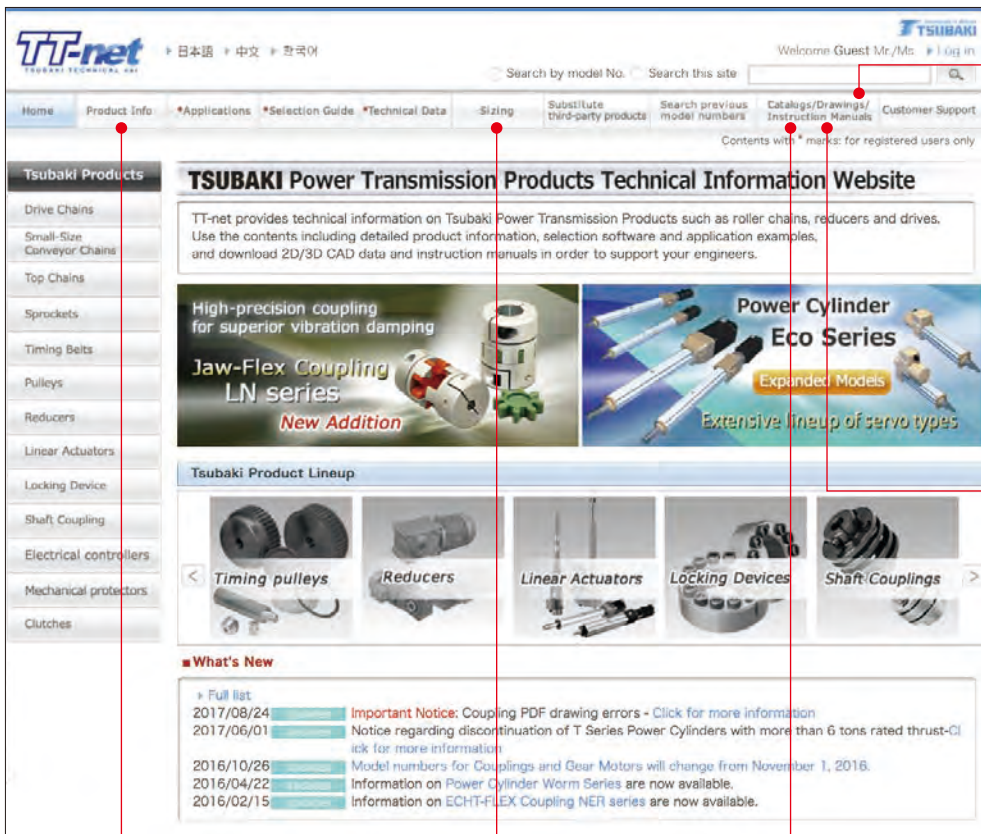

**Drawings**

Download 3D-CAD data, DXF drawings, and PDF files.



**Instruction Manuals**

Download instruction manuals.

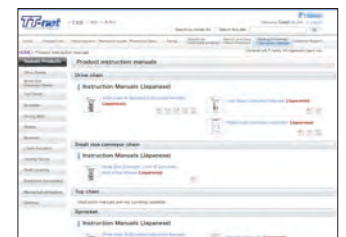

**Product Info**

Browse product features and specifications.



**Sizing**

Find more information on choosing the appropriate model for your application.



**Catalogs**

Choose from a range of catalogs and pamphlets to download.



# SHOCK RELAY

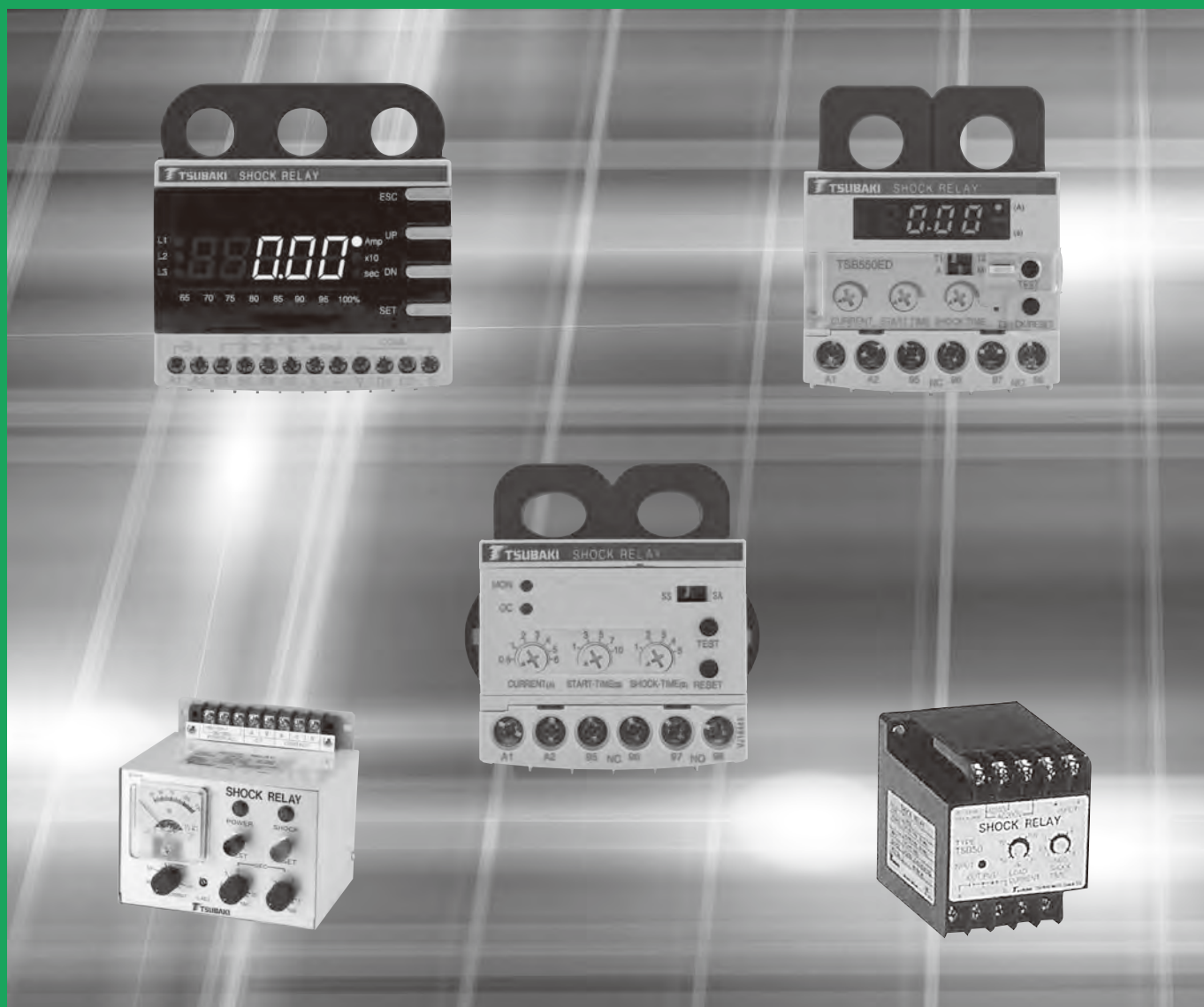

Features ..... p7

Applications ..... p8

Series reference chart ..... p9

Notes when selecting: ..... p10

Special models and  
optional specifications

Shock Relay SC Series ..... p11

Shock Relay ED Series ..... p22

Shock Relay 150 Series ..... p25

Shock Relay SB Series ..... p29

Shock Relay 50 Series ..... p32

# Shock Relay

## Quickly detects equipment overload!

The Shock Relay is a current monitoring device that quickly detects motor overload, thus protecting your equipment from unexpected damage.



## Features

### 1. Instantly detects overcurrent

When the motor current exceeds the predetermined current value, the relay contact signal can be output after a preset time.

For example, when a foreign object gets caught up in the conveyor, the Shock Relay sends a signal causing an emergency stop, thus minimizing equipment damage.

#### It's not a thermal relay

The purpose of the thermal relay is to protect the motor from burnout. When the motor current continually exceeds the rated value for a certain period of time, an emergency signal is sent to protect the motor from burnout. Generally, it takes a long time for operation to begin, so it is not suitable for equipment/machine protection.

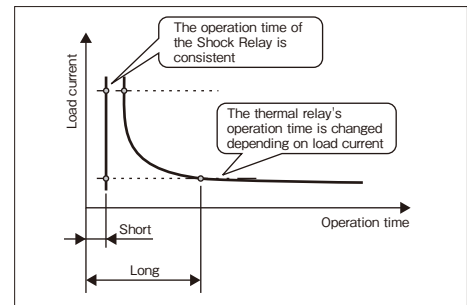

	Operation time	Protected object
Shock Relay	Short	Equipment
Thermal Relay	Long*	Motor

\* If the motor current slightly exceeds the preset value, the thermal relay will not work. Even if it does work, it will do so slowly.

### 2. Easy to install on existing equipment

The Shock Relay is an electrical protection device. When adding the Shock Relay to existing equipment, it is not necessary to make major modifications to the equipment as in the case of mechanical protection devices.

Because the Shock Relay is installed inside the control panel, it can function outdoors or in harsh environments.

	Existing equipment	Environment
Electrical	Easy to install later	Built inside the panel
Mechanical	Difficult to install later	Necessary environmental precautions

### 3. The emergency signal is only output under abnormal conditions

The Shock Relay sends an emergency signal when overcurrent continues to exceed the preset period of time.

Sometimes during normal operation, conveyors will experience insignificant short-term current overloads due to reasons such as the current pulsation of the equipment, or when packages are put on the conveyor. By using the shock time function these small overloads will not be recognized as overloads, therefore avoiding nuisance stoppages.

## Operation time chart

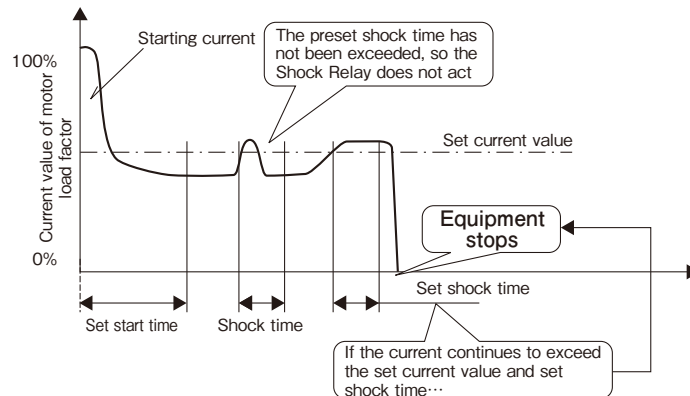



## Applications

### SC Series

#### Mixer



#### Operation

1. When mixing has just started and the load is heavy, the mixer operates at a low speed.
2. When the load becomes lighter after some time of mixing, an output signal of 4 to 20 mA is sent to a sequencer to switch the mixing to a higher speed.

#### Key points

Output of 4 to 20 mA enables action according to the actual load.



### ED Series

#### Lifting device for lighting and screens



#### Operation

1. Due to over-installation of the lighting system, when the total weight of the baton exceeds the permissible load, the lifting device will be automatically shut down.
2. When the lifting device becomes overloaded during operation it automatically shuts down.

#### Key points

During operation the motor current is displayed digitally, and allowable load and stopping due to overload can be set as a digital numeric value.

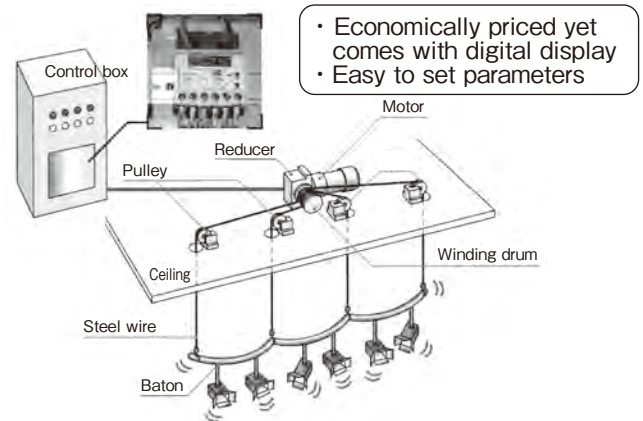

### SB Series

#### Chip conveyor



#### Operation

Protects the conveyor from damage when a tool gets caught in its belt.

#### Key points

The drive can be compact and less expensive.

Note: We can also provide a Shock Relay built into the gear motor terminal box.

- Ideal for hollow type reducers (for applications where it is difficult to install a mechanical safety device)
- Easy to change settings
- Smaller than a mechanical safety device, even for large-capacity motors

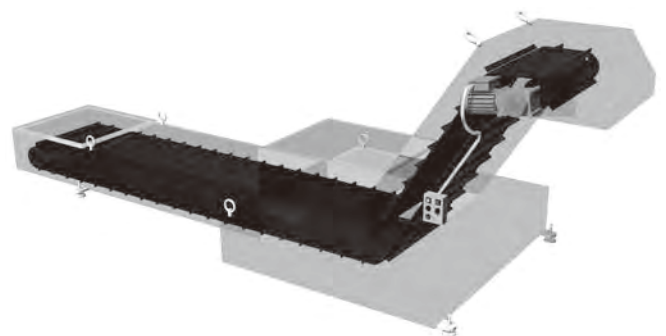

# Shock Relay

## Series reference chart

Series name		SC Series		ED Series		150 Series		SB Series		50 Series	
Model no.		TSBSCB/S06 to TSBSCB/S60		TSB020ED to TSB550ED		TSB151, 152		TSBSA05 to 300		TSB50	
Features		Digital display, communication function, self-holding or automatic reset		Digital display, economical, self-holding or automatic reset		Analog display, self-holding		Economical, self-holding or automatic reset		Economical, automatic reset	
Motor	(kW)										
	Combined with external CT										
Power source (V)		200/220	400/440	200/220	400/440	200/220	400/440	200/220	400/440	200/220	400/440
Operation setting level		Ampere (A)		Ampere (A)		Ratio to motor rated current value (%)		Ampere (A)		Ratio to motor rated current value (%)	
Start time setting range		0.2 to 12.0s adjustable		0.2 to 10.0s adjustable		0.2 to 20s adjustable		0.2 to 10s adjustable		3s (fixed)	
Shock time setting range		0.2 to 5.0s adjustable		0.2 to 5.0s adjustable		0.2 to 3s adjustable		0.2 to 5.0s adjustable		0.3 to 3s adjustable	
Operating power supply voltage		AC100 to 240V		DC/AC24 to 240V		AC100/110V or AC200/220V, 50/60Hz		DC/AC24 to 240V		AC100/110V or AC200/220V, 50/60Hz	
Condition of output relay after activation		Selectable; self-holding or automatic reset		Selectable; self-holding or automatic reset		Self-holding		Selectable; self-holding or automatic reset		Automatic reset	
Test function		○		○		○		○		×	
Operation display		LED digital display		LED digital display		LED light		LED light		×	
Open phase, phase reversal, phase unbalance detection*1		○		×		×		×		×	
Alarm output		○		×		×		×		×	
DIN rail mounting		○		○		×		○		×	
Display		Digital current value		Digital current value		Analog %		×		×	
CT (current transformer)		Built-in (for large-capacity external CT)		Built-in		Separate external CT		Built-in (for large-capacity external CT)		Separate external CT	
*3 Special models	Impact load detection	×		×		△		×		×	
	1A input	×		×		△		×		×	
	Upper/lower limit detection	○		×		△		×		×	
*3 Additional specifications	cUL certification	×		○		×		○		×	
	CE marking	○		○		×		○		×	
	CCC certification	×		○		×		○		×	
	Subtropical specifications	×		×		△		×		△	
	Control power supply voltage modification	× *2		× *2		△		× *2		△	
	Panel mounted	○*4		×		△		×		×	
	Start time modification	×		×		△		×		△	
Shock time modification	×		×		△		×		△		
Automatic reset	○		○		△		×		○		

○···Standard △···Made to order ×···Not available

Notes: \*1. Open phase·····The motor lacks one phase.

Phase reversal ······The phase of the power supply to the motor becomes inverted.

Phase unbalance ······The phase current becomes unbalanced. The maximum value of the phase current is detected when it is greater than or equal to 2 x the minimum value.

\*2. Even if the voltage for operation is not standard, it is possible to use the standard units if the voltage fluctuation is taken into consideration and the voltage is within the above range.

\*3. For more information, refer to page 10.

\*4. Panel mounted type must be selected.

## Notes when selecting

1. When used with human transportation equipment or lifting devices, install a suitable protection device on that equipment/device for safety purposes. Otherwise an accident resulting in death, serious injury, or damage to equipment may occur.

### 2. CT (current transformer)

The CT is essential for current detection (150 Series, 50 Series only). For more information about the appropriate CT, refer to the page of each series.

### 3. Model selection for special capacity and/or motor voltage

Normally a Shock Relay can be selected by motor capacity, but when the motor capacity and/or motor voltage is special (a standard Shock Relay can be used up to a maximum of 600V), select a Shock Relay based on the motor rated current value (set current range).

### 4. Operating power supply voltage

The operating power supply voltage described in the chart is the standard. For operating power supply voltages other than the standard, the 150 Series is available for special operating power supply voltage as a special MTO product.

### 5. Output relay operation

The output relay operation consists of two modes: the activation type and the reverting type when overcurrent is detected.

In the event of a power outage, make sure to switch off the machine as the sudden activation of the output relay may cause an accident or equipment damage.

#### 1) Activation when overcurrent is detected

The output relay is activated (contact inverts) only when overcurrent is detected.

**Corresponding models** ED Series, SB Series (auto reset), 150 Series, 50 Series

#### 2) Reverting when overcurrent is detected

When the power source for the Shock Relay is ON, the output relay is activated (contact inverts). The output relay, which was activated when overcurrent was detected returns to its original state.

**Corresponding model** SB Series (self-holding)

### 3) Activation or reverting

It is possible to switch between these two modes.

**Corresponding model** SC Series

## 6. Self-holding and automatic reset

The methods used for output relay resetting are self-holding and automatic reset.

### 1) Self-holding

Even after overcurrent has stopped, the self-holding mode continues to function. In order to return it to normal operation, push the RESET button or cut the operation power supply.

**Corresponding models** 150 Series

### 2) Automatic reset

The output relay automatically resets after overcurrent is gone.

**Corresponding models** 50 Series

### 3) Self-holding or automatic reset

It is possible to switch between these two modes.

**Corresponding models** ED Series, SC Series, SB Series

## 7. Inverter drive applicability

1) Detection accuracy decreases but generally if it is within the 30 to 60 Hz range, it can be used.

2) Even within the 30 to 60 Hz range, when the inverter accelerates and decelerates, and the current increases or decreases, the Shock Relay can sometimes cause an unnecessary trip. Slowly accelerate and decelerate or set it so that there is some leeway in load current within the allowable range.

3) Connect the CT to the secondary side of the inverter, but make sure to connect the Shock Relay operation power source to a commercial power source (never connect it to the secondary side of the inverter).

## 8. Note

When the inertia of the equipment/machine is large or the speed reduction ratio is large, the Shock Relay may sometimes not work. Conduct a trial test first before putting it into regular use. The default knob settings for start time/shock time is "min", while current is "max".

 Refer to the manual for further details.

## Outline of special models (Special models are available based on the 150 Series)

Special models	Outline of specifications	Special model no.
Impact load detection	Separately from the usual overload, abnormally large current is instantly detected and output. Impact load can be set from 30%–300%. Impact load shock time is within 0.05s. Other functions and outline dimensions conform to standard products.	TSB151M TSB152M
1A input	When the secondary side of CT is 1A, it can input directly to the Shock Relay. (It's not necessary to consider motor capacity.) Other specifications and outline dimensions conform to standard products.	TSB152C
Upper/lower limit detection	Detects both overload and under-loads; however, because there is only one output relay, it cannot distinguish between upper and lower limits.	TSB151W TSB152W

## Outline of optional specifications (Optional specifications are available based on the 150 or 50 Series)

Optional specifications	Outline of specifications	Order symbol
Subtropical specifications	Can be used when ambient humidity is 90% RH and below. Other specifications conform to standard products.	S
Control power supply voltage modification	Voltage: AC230V, AC240V, AC115V, AC120V (Contact us for more information on other voltages.)	V
Panel mounted	It can be mounted on the control panel surface and operated.	P
Start time modification	The integral multiple can be extended for a maximum of 60 seconds. The front panel scale becomes an integral multiple (x2, x3 ...). Other specifications conform to standard products.	T1
Shock time modification	The integral multiple can be extended for a maximum of 60 seconds. The front panel scale becomes an integral multiple (x2, x3 ...). Other specifications conform to standard products.	T2
Automatic reset	For the 150 Series only, the output relay can be changed from self-holding to automatic reset.	H



# Shock Relay SC Series

## Features

- **Communication function allows central monitoring of process loads**  
Users can check the condition of the Shock Relay at each process and change settings remotely via PCON monitoring software.
- **4 to 20 mA output**  
Users can check and analyze the load record and its operation.
- **Face mount (panel type)**  
A panel-type model is available. The display portion can be separated from main unit, and can be installed at the control box panel.
- **Undercurrent detection**  
Selectable output contacts: alarm output or lower-limit current detection output
- **Maintenance indicator**  
Set the operational time until the next maintenance, and a notification will be given when the time is reached.
- **Thermal relay function (inverse time characteristic)**  
Switch to electrical thermal energy to protect the motor from burnout.
- **CE marking**
- **RoHS compliant**
- **Works with an inverter\***

The SC Series can precisely detect current during inverter driving at frequencies of 20 to 200 Hz.

\* To prevent unnecessary operation of the Shock Relay due to the increase in current during acceleration/deceleration, accelerate or decelerate slowly or allow a margin in the preset current.

### All-in-one type

TSBSCB06  
TSBSCB34  
TSBSCB60



### Panel type

TSBSCS06 + TSBSCD + TSBSCC05~30  
TSBSCS34 + TSBSCD + TSBSCC05~30  
TSBSCS60 + TSBSCD + TSBSCC05~30

## Standard specifications

Model no.		All-in-one type	TSBSCB06	TSBSCB34	TSBSCB60	
		Panel type	TSBSCS06	TSBSCS34	TSBSCS60	
Motor	200V class	Number of wires passing through CT	4t	—	—	
			2t	0.1kW	1.5, 2.2kW	
			1t	0.2, 0.4kW	3.7, 5.5kW	
	400V class		4t	0.75kW	—	7.5, 11kW
			2t	0.2kW	—	—
			1t	0.4, 0.75kW	2.2, 3.7, 5.5kW	—
			1.5kW	7.5, 11kW	15, 18.5, 22kW	
Frequency of detected current		20 to 200Hz				
Maximum motor circuit voltage		AC690V 50/60Hz				
Operating power source		100 to 240VAC±10%, 50/60Hz				
Protection functions	Overcurrent setting	Number of wires passing through CT	4t	0.15 to 1.60A (0.01A)	—	( ): Increment
			2t	0.30 to 3.20A (0.02A)	3.00 to 17.0A (0.1A)	—
			1t	0.60 to 6.40A (0.04A)	6.00 to 34.0A (0.2A)	10.00 to 60.0A (0.4A)
	Start time		0 to 12.0s (0.2s and larger: 0.1s increments)			
	Shock time		0.2 to 5.0s (0.1s increments)			
	Accuracy	Current detection accuracy		±5% (for commercial power source)		
		Temporal accuracy		±5%		
	Under current		Trip at 0.2 to 5s (OFF: No action)			
	Lock when starting up		Set at 2 to 8 times of overcurrent setting value (OFF: No action) Trip after Start time + 0.2s when starting up			
	Lock when operating		Set at 1.5 to 8 times of overcurrent setting value (OFF: No action), trip at 0.2 to 5s			
	Phase reversal		Trip within 0.15s (OFF: No action)			
	Open phase		Trip at 0.5 to 5s (OFF: No action)			
	Imbalance		Trip at 1 to 10s (OFF: No action) when setting at 10 to 50%			
Alarm		Output when A, F and H are set (OFF: No action)				
Running hour		Trip when 10 to 9990hr is set (OFF: No action)				
Fail-safe		Activated when setting ON (Conducting normally: Excited, Trip: Non-excited)				
Output relay	Rated load		3A, 250VAC (cos φ = 1)			
	Minimum allowable load*1		DC24V, 4mA			
	Life		100,000 activations at rated load			
	Contact arrangement		OC: 1c, AL/UC/TO: 1a			
Reset	Self-holding		E-r: Manual release or resetting of power source, H-r: Manual release			
	Auto reset		A-r: Auto-reset and return time set at 0.2s to 20min			
Analog output		Analog output 4 to 20mA DC output (OFF: No action), Allowable load resistance: 100Ω or less				
Communication output		RS485/Modbus				
Insulation resistance (between housing-circuit)		DC500V 10MΩ				
Withstand voltage	Between housing-circuit		2000VAC 60Hz 1min.			
	Between relay contacts		1000VAC 60Hz 1min.			
Usage environment	Location		Indoors, where it will not get wet			
	Ambient temperature		— 20 to + 60 °C			
	Ambient humidity		30 to 85% RH (no condensation)			
	Altitude		2000m or less			
	Atmosphere		No corrosive gas, oil-mist, or dust			
	Vibration		5.9m/s <sup>2</sup> or less			
Power consumption		7VA or less				
Approx. mass		0.3kg or less				

\*1: When directly inputting output relay contact into the programmable controller (PLC), be aware that a minute electric current can cause contact failure. Therefore, input the output relay contact via a minute-current relay.

# Part names and functions

## All-in-one type



## Panel type

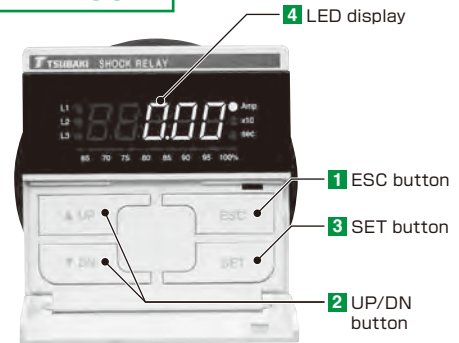

### 1 ESC button (reset)

Releases the trip or returns the settings screen to the initial screen.  
Push the reset button after completing parameter settings to return to the initial screen.

### 2 UP/DN button (UP/DOWN)

Switches to parameter mode and changes data settings.

### 3 SET button (set)

Confirms and registers parameter setting data.

### 4 LED display

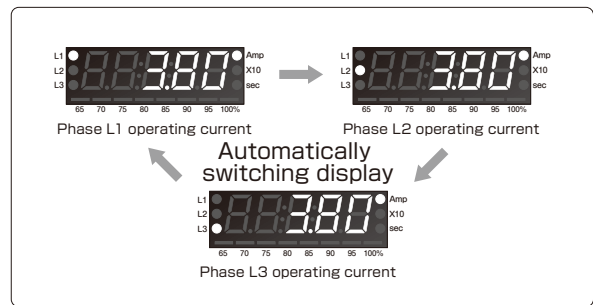
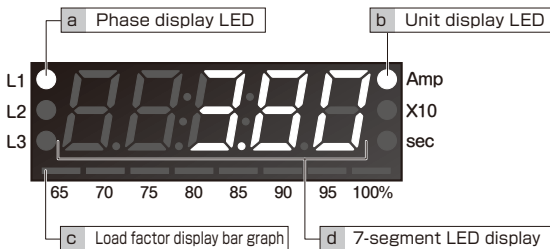

- a. Phase display LED  
Displays the phase (L1 →L2 →L3) that shows the current.  
Changes every two seconds.
- b. Unit display LED  
Indicates the unit.
- c. Load factor display bar graph  
Can be utilized as a guide when setting OC (overcurrent setting value).  
Displays the ratio of operational load current to OC current set value (load factor) in percentage (%).
- d. 7-segment LED  
Displays operating current, parameter set values, cause of trip, etc.

### Digital ammeter functions

- 1) While in normal operation, users can change the displayed phase, and set it by pushing the SET button. Release by pushing the ESC button.
- 2) Trip records (3 most recent) can be viewed by pushing and holding the ESC button 5 sec. or longer. Push the UP/DN buttons to cycle through and confirm current values (phases L1 →L2→L3→L1→...). The order of the trip record appears on a bar graph in the order of 100%, 95%, and 90% for easy confirmation. Release by pushing the ESC button.

### 5 Terminal arrangement

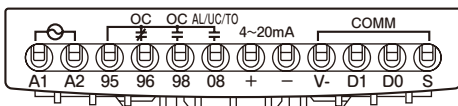

#### Applicable wire

Wire: ISO 1 to 2.5mm<sup>2</sup>, AWG#18 to 14, 75°C copper wire  
Strip length: 8mm  
No. of connectable wires: Up to 2 for one terminal  
Tightening torque: 0.8 to 1.2N·m

Terminal symbol	Function	Explanation
A1, A2	Operational power supply	Connects AC100 to 240V commercial power supply
95	Common contact	Terminal 96, 98, 08 common contact
96	OC output	b contact: Normally closed, open during overcurrent (FS: When OFF)
98		a contact: Normally open, closed during overcurrent (FS: When OFF)
08	AL/TO/UL output	Alarm output, running hour output, undercurrent output
+	Analog output	Outputs analog current DC4 to 20mA
-		
V-, D1, D0, S	Terminal for communication	Connect when using communication function

# Shock Relay SC Series

## Operating mode

### Overload operating mode

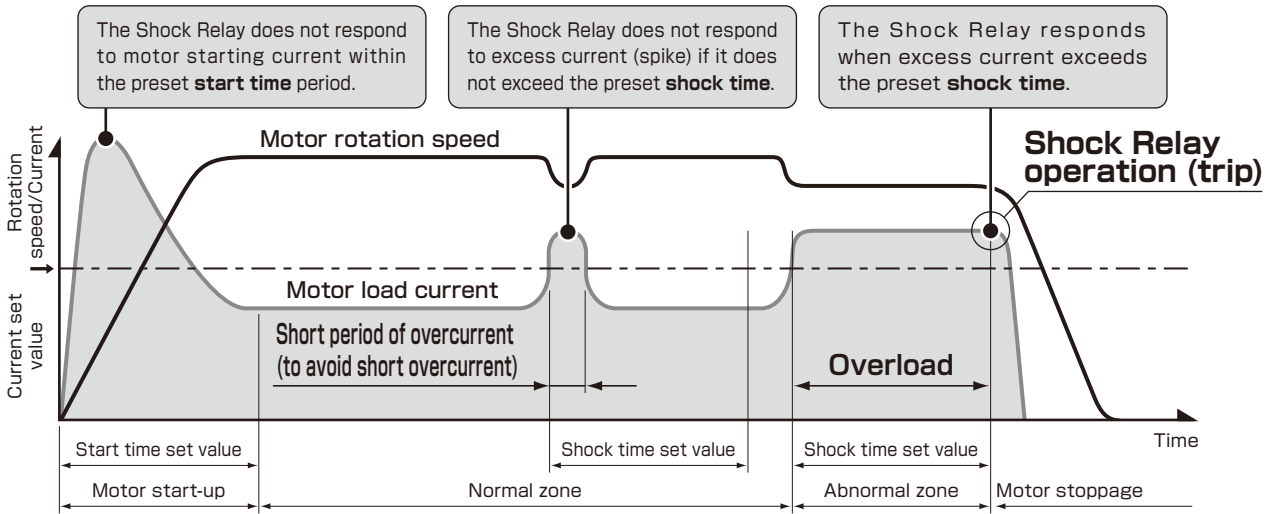

### Light-load operating (undercurrent detection) mode

Once the motor current falls below the preset level, it is detected and a signal is sent to stop the motor.

Note: For lower-limit detection, the output contact is either alarm output.

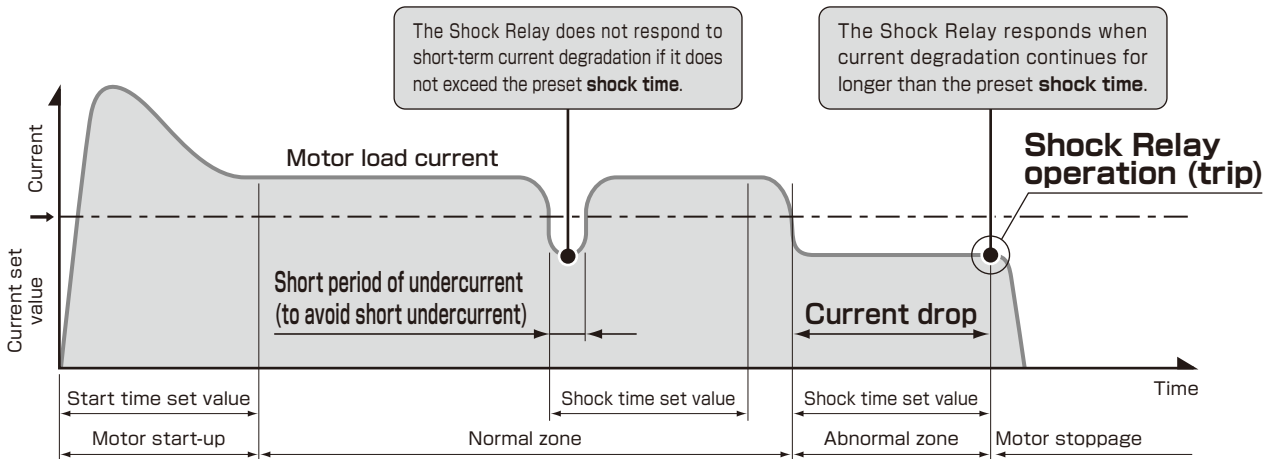

## Model

**All-in-one type**

**Main unit**

**TSBSCB06**

Shock Relay

SC Series

Type B: All-in-one

Load current (Max. set current value)

06 : 6A  
34 : 34A  
60 : 60A

**External CT (for SC Series only)**  
In case current setting range is over 60A, use with TSBSCB/S06 as a set.

**TSB3CTC100**

Shock Relay

3-phase CT For SC Series

Rated current

100 : 100A  
200 : 200A  
300 : 300A

**Panel type**

**Main unit (for panel type)**

**TSBSCS06**

Shock Relay

SC Series

Type S: Panel

Load current (Max. set current value)

06 : 6A  
34 : 34A  
60 : 60A

**Panel unit (for panel type)**

**TSBSCD**

Shock Relay

SC Series

Panel

**Cable (for panel type)**

**TSBSCC05**

Shock Relay

SC Series

Cable

Cable length

05 : 0.5m  
10 : 1.0m  
15 : 1.5m  
20 : 2.0m  
30 : 3.0m



# Unique functions of the SC Series

## Communication function

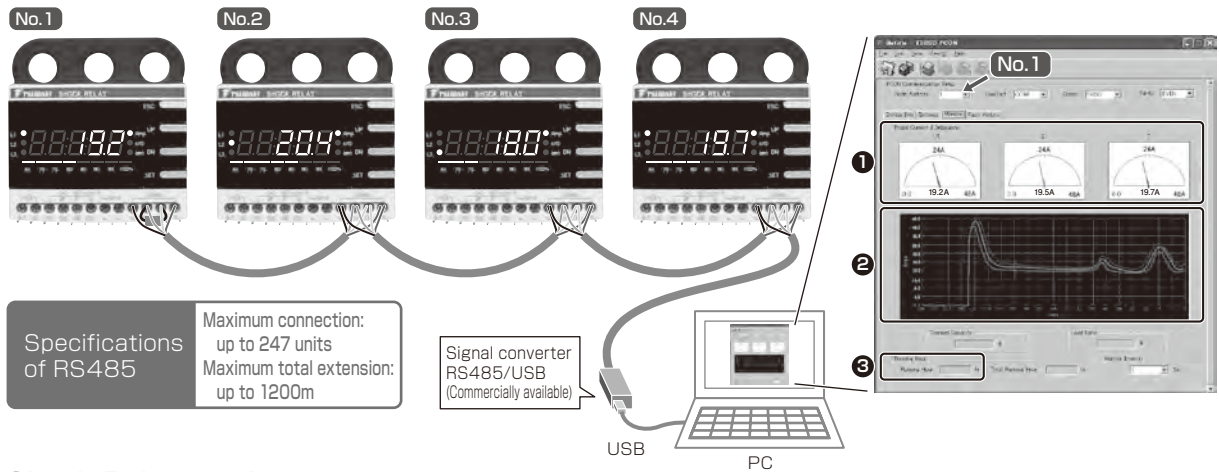

## Shock Relay settings



- 1) **Set value read-in**  
Reads in the set values from a specified Shock Relay address and displays them on the PC screen.
- 2) **Set value writing**  
Set values edited on the PC can be written to a specified Shock Relay address.
- 3) **Set value back-up**  
Set values edited on the PC can be backed up to a text file.

- 1 **Remote control** — Displays the current of each phase L1, L2, and L3 on the PC screen by reading them from a specified Shock Relay address.
- 2 **Current change display** — Plots the current value of each phase at specified intervals. Data for the last 159 times can be displayed.
- 3 **Accumulated operation time display** — Can be used for maintenance such as lubrication and filter cleaning.

## Trip record



### Three most recent trip records

The three most recent trip records of a designated Shock Relay is displayed on the screen.

- 1 Cause of trouble
- 2 Phase that caused trouble
- 3 Current value when trouble happened
- 4 Set value when trouble happened

## 4 to 20 mA analog signal

### What is a 4 to 20 mA analog signal?

A 4 to 20 mA analog signal is a standard instrumentation signal used around the world.

Instrumentation signal:

- Voltage signal: DC 0 to 5 V, DC 0 to 10 V, etc.
- Current signal: DC 0 to 20 mA, DC 4 to 20 mA, etc.

Current signals are less susceptible to influence from noise than voltage signals.

In addition, DC 4 to 20 mA, when compared to DC 0 to 20 mA, is more precise in the event of wire disruption or breaks. Therefore, DC 4 to 20 mA is used frequently, specifically in the case of long transmission distances (several tens of meters) or for reducing noise influence.

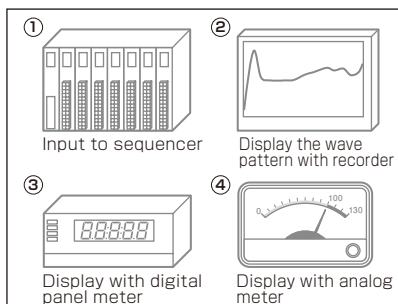

### Application examples

- 1 Automatic control of the input and viscosity depending on the load by inputting the load current of a crusher or mixer to the sequencer.
- 2 Figuring out the operation and loading conditions for the equipment by recording the load current of a trial unit, and using it as the basis for an optimal equipment design.
- 3, 4 Activation of a digital or analog meter with DC 4 to 20 mA signal for remote centralized monitoring of pumps, etc.

In the case of TSBSCB60 (max. 60A), it is possible to transmit DC 0 to 60 A as a DC 4 to 20 mA signal. In addition, output value correction is available due to the scaling adjustment function of the DC 4 to 20mA output of the TSBSC Series.

4 to 20 mA signal

## Setup steps

Item	Operation button	Operation instruction
1. Selection of parameter	UP/DN	Press the UP/DN button to select the parameter to be set.
2. Preparation for setting	SET	The set value begins blinking when the SET button is pressed after selecting a parameter.
3. Selection of setting	UP/DN	Press the UP/DN button until the desired set value is shown.
4. Registration of setting	SET	Press the SET button after selecting the set value. The blinking value indication becomes lighted and the set value is registered.
5. Initial screen	ESC	Press the ESC button to return to the initial display after completing the settings. If no button is pressed, the display automatically returns to the initial screen after 50 seconds.

## Parameters

No.	Menu	Parameter		Explanation of function																																															
		Initial value	Set value																																																
1	Parameter lock	PE: 0	0	All parameter settings are possible.																																															
			1	To lock parameter settings, input "1" for every parameter set. To unlock the setting, input "1", then "0". When PE: --- is displayed, the setting is completed.																																															
2	Selection of phase no.	Ph: 3Ph	3Ph	Monitors 3-phase motor.																																															
			1Ph	Monitors single-phase motor.																																															
3	Upper limit detection operating characteristics	LcCdE	dE	Operates with definite time characteristics.																																															
			th	Operates with inverse time characteristics and is cumulative, similar to thermal characteristics. (Refer to "Thermal characteristics" chart on page 18.)																																															
			In	Operates with inverse time characteristics. (Refer to "Inverse characteristics" chart on page 18.)																																															
			no	Disables upper limit detection.																																															
4	CT ratio	ct: 1t	1t, 2t, 4t	Sets the number of motor wires that pass through the CT (1t: once, 2t: twice, 4t: 4 times) Type 34: only 1t and 2t; Type 60: only 1t																																															
			100, 200, 300	Select when using an external CT (Type 06 only)																																															
5	Fail-safe	FS: off	off	<input type="checkbox"/> Normal mode When a trip occurs, the relay turns ON (95-96: Open; 95-98: Closed).																																															
			on	<input type="checkbox"/> Fail-safe mode After the power is turned on, the relay turns ON (95-96: Open; 95-98: Closed); and when a trip occurs, the relay turns OFF (95-96: Closed; 95-98: Open). <u>This setting becomes effective after a power reset.</u>																																															
6	Phase reversal detection	rP: off	off	Set to "on" for when detecting phase reversal.																																															
			on																																																
7	Overcurrent setting	oc: 6.40	See right	Sets the current value for overcurrent. For type 34 and 60, the current value cannot be set over 32A for inverse time characteristics "th" and "In".																																															
				<p><b>● Current setting table</b> <span style="float: right;">Unit: (A)</span></p> <table border="1"> <thead> <tr> <th rowspan="2">CT Ratio</th> <th colspan="2">06 type</th> <th colspan="2">34 type</th> <th colspan="2">60 type</th> </tr> <tr> <th>Setting range</th> <th>Increment</th> <th>Setting range</th> <th>Increment</th> <th>Setting range</th> <th>Increment</th> </tr> </thead> <tbody> <tr> <td>1t</td> <td>0.60 to 6.40</td> <td>0.04</td> <td>6.00 to 34.0</td> <td>0.2</td> <td>10.0 to 60.0</td> <td>0.4</td> </tr> <tr> <td>2t</td> <td>0.30 to 3.20</td> <td>0.02</td> <td>3.00 to 17.0</td> <td>0.1</td> <td rowspan="3" style="text-align: center;">/</td> <td rowspan="3" style="text-align: center;">/</td> </tr> <tr> <td>4t</td> <td>0.15 to 1.60</td> <td>0.01</td> <td></td> <td></td> </tr> <tr> <td>100</td> <td>12.0 to 128</td> <td>1</td> <td></td> <td></td> </tr> <tr> <td>200</td> <td>24.0 to 256</td> <td>1</td> <td></td> <td></td> <td></td> <td></td> </tr> <tr> <td>300</td> <td>36.0 to 384</td> <td>1</td> <td></td> <td></td> <td></td> <td></td> </tr> </tbody> </table>	CT Ratio	06 type		34 type		60 type		Setting range	Increment	Setting range	Increment	Setting range	Increment	1t	0.60 to 6.40	0.04	6.00 to 34.0	0.2	10.0 to 60.0	0.4	2t	0.30 to 3.20	0.02	3.00 to 17.0	0.1	/	/	4t	0.15 to 1.60	0.01			100	12.0 to 128	1			200	24.0 to 256	1					300	36.0 to 384	1
CT Ratio	06 type		34 type			60 type																																													
	Setting range	Increment	Setting range	Increment	Setting range	Increment																																													
1t	0.60 to 6.40	0.04	6.00 to 34.0	0.2	10.0 to 60.0	0.4																																													
2t	0.30 to 3.20	0.02	3.00 to 17.0	0.1	/	/																																													
4t	0.15 to 1.60	0.01																																																	
100	12.0 to 128	1																																																	
200	24.0 to 256	1																																																	
300	36.0 to 384	1																																																	

# Parameters

No.	Menu	Parameter		Explanation of function
		Initial value	Set value	
8	Start time	dt: 02.	0	When setting the inverse time characteristic "In", it operates in Cold curve characteristic from motor start-up until the current becomes lower than the OC setting. After that, it operates in Hot curve characteristic.
			0.2 to 12.0s	The relay is not output within the time setting, so as not to operate when the motor starts. When inverse time characteristic "In" is set, it operates in Hot characteristic after start time.
9	Overcurrent shock time	ot: 02.	0.2 to 5.0s	Sets continuous overload time of the overcurrent setting.
		cls: 1.	1 to 30	Selects the operation characteristic when inverse time characteristic "th" or "In" are set. (Refer to thermal and inverse characteristics charts.)
10	Under-current setting	ucOFF	oFF	Sets current value for detecting lower limit. This cannot be set higher than the overcurrent value. Relay output for lower limit detection is as follows: Alarm ALo is set to "except uc": Outputs at OC contact Alarm ALo is set to "uc": Outputs at AL/UC/TO contacts
			See right	
11	Under-current shock time	ut: 02.	0.2 to 5.0s	Set continuous lower limit detection time of under-current setting.
12	Open phase	PLoFF	oFF	Set to "on" for when detecting open phase.
			on	
13	Open phase operating time	PLt05.	0.5 to 5s	Sets operating time for when detecting open phase. When open phase detection is set to oFF, it is not displayed.
14	Imbalance setting	UbOFF	oFF	Set to 10 to 50% for when detecting imbalance.
			10 to 50%	Imbalance rate (%) = $\frac{(\text{Max. current} - \text{Min. current})}{\text{Max. current}} \times 100$
15	Imbalance operating time	Ubt: 1	1 to 10s	Sets operating time for when detecting imbalance. When imbalance detection is set to oFF, it is not displayed.
16	Lock when starting	ScOFF	oFF	Sets the ratio against overcurrent setting for when detecting locked start-up. Setting range: Sc setting value $\times \text{OC} \leq 250\text{A}$ . When the start time is set to 0s, it is not displayed.
			2 to 8 times	
17	Lock when operating	JAoFF	oFF	Sets the ratio against overcurrent setting for when detecting locked operation. Setting range: JA setting value $\times \text{OC} \leq 250\text{A}$ .
			1.5 to 8 times	
18	Jam fault duration	Jt: 02.	0.2 to 5s	Sets the operating time for when detecting locked operation. When set to oFF, it is not displayed.
19	Analog output range	r5640	See right	Sets the current value as analog current output scale for 20mA output. Refer to page 15 "Current setting table" for setting range.
			oFF	Set when disabling analog current output.
20	Alert	ALo no	no	Set when disabling alarm output.
			A	Set when enabling alarm output. Refer to the table on page 17.
			F	
			H	
			to	Triggers an output when the running hour is set.
			uc	Set for when detecting lower limit.
ALoFF	oFF	Set the ratio against the OC current for when outputting an alarm.		
		50 to 100%		



## Parameters

No.	Menu	Parameter		Explanation of function
		Initial value	Set value	
21	Reset		E-r	Self-holding after trip. Returns when power is reset or ESC button is pushed.
			H-r	Self-holding after trip. Returns when ESC button is pushed.
			A-r	Automatic reset after trip.
			0.2s to 20min	Sets automatic reset time.
22	Reset limitation		oFF	There is no limit to the number of resets.
			1 to 5	Sets the number of reset operations (within 30 minutes).
23	Total running hour		/	Displays total running hours.
24	Running hour		/	Displays operating time since inputting the running hours setting time.
25	Running hour setting		oFF	To output the running hours, set the number of hours. The running hours will be counted from the point when the input is completed.
			10 to 99990hr	
26	Communication setting		1 to 247	Sets the communication address.
			See right	Sets the communication speed 1.2, 2.4, 4.8, 9.6, 19.2, 38.4 kbps.
			odd, Evn, non	Sets the parity.
			oFF, 1 to 999s	Sets the waiting time until an error is displayed when there is communication trouble.
27	Test mode		/	When the set button is pushed when this is displayed, after three seconds plus Shock Time,  is shown and relay is output.

## Alarm

Operating mode	When motor starts	Normal operation	When exceeding alarm set value	When tripping
Operational output				
Flicker output				
Hold output				

## Trip display

Trip function	Indication	Details of trip	Solution
Overcurrent		After the preset start time period, a current exceeding the upper limit current continued to flow longer than the preset shock time. Trip current is 3.6A.	Check for any anomalies of the machine
Open phase		Tripped due to open phase of R(L1) phase.	Check for any anomalies of the machine
Phase reversal		Tripped due to phase reversal.	Check phase sequence with phase sequence meter
Stall (Lock when starting)		When the motor started, a current exceeding the Sc set value continued to flow longer than the preset start time.	Check for any anomalies of the machine
Jam (Lock when operating)		When the motor was operating, a current exceeding the Ja set value continued to flow longer than the Jt preset time.	Check for any anomalies of the machine
Imbalance		The current of each phase became imbalanced larger than the Ub set value and continued to remain imbalanced longer than the Ubt preset time.	Check power source, motor, and motor wiring
Under-current		After the preset start time period, a current lower than the lower limit current continued to flow longer than the preset shock time. Trip current is 1.6A.	Check for any anomalies of the machine
Reset limitation		The number of auto resets after tripping exceeded the set value within 30 minutes.	Check for any anomalies of the machine

# Inverse-time characteristics charts

## Thermal characteristics

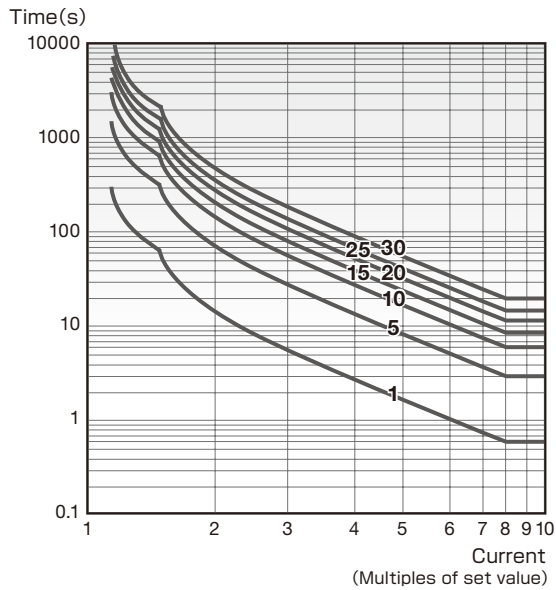

## Inverse characteristics

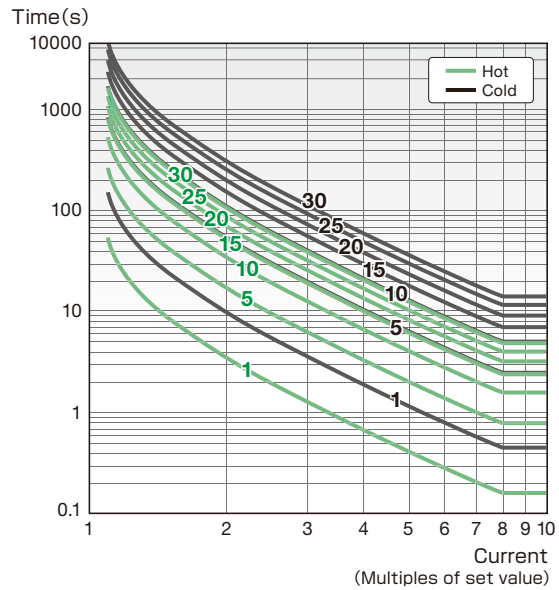

## Number of motor wires that pass through the CT (current transformer)

Refer to the table below for the number of motor wires that pass through the CT. The values in this table are just a guide for when the motor is used at load factors of 80 to 100%. If the motor load factor is low, increase the number of wires passing through to improve the setting accuracy.

In addition, for motors not in the table below (small, single phase, different voltage, etc.), select and set an appropriate model and the number of wires passing through the CT based on the set current values.

3-phase AC 200V class motor		
kW	Shock Relay model no.	Number of wires passing through CT
0.1	TSBSCB/S06	4
0.2	TSBSCB/S06	2
0.4	TSBSCB/S06	2
0.75	TSBSCB/S06	1
1.5	TSBSCB/S34	2
2.2	TSBSCB/S34	2
3.7	TSBSCB/S34	1
5.5	TSBSCB/S34	1
7.5	TSBSCB/S60	1
11	TSBSCB/S60	1
—	—	—
—	—	—
—	—	—

3-phase AC 400V class motor		
kW	Shock Relay model no.	Number of wires passing through CT
—	—	—
0.2	TSBSCB/S06	4
0.4	TSBSCB/S06	2
0.75	TSBSCB/S06	2
1.5	TSBSCB/S06	1
2.2	TSBSCB/S34	2
3.7	TSBSCB/S34	2
5.5	TSBSCB/S34	2
7.5	TSBSCB/S34	1
11	TSBSCB/S34	1
15	TSBSCB/S60	1
18.5	TSBSCB/S60	1
22	TSBSCB/S60	1

Notes: 1) Set the parameter "CT ratio" based on the number of wires passing through the CT.  
2) If motor capacity exceeds the above table, use an external CT.

## Specifications of external CT

Model no.		TSB3CTC100	TSB3CTC200	TSB3CTC300	
External CT	Class	Grade 3			
	Rated primary current	100A	200A	300A	
	Rated secondary current	5A			
	Rated burden	5VA			
	Rated frequency	50/60Hz			
Mass		0.9kg			
For ref.	Applicable main unit model no.	TSBSCB/S06			
	Motor	200V class	15 to 18.5kW	22 to 37kW	45 to 75kW
		400V class	30 to 45kW	55 to 90kW	110 to 132kW

# Shock Relay SC Series

## Connection diagram

### Basic connection diagram

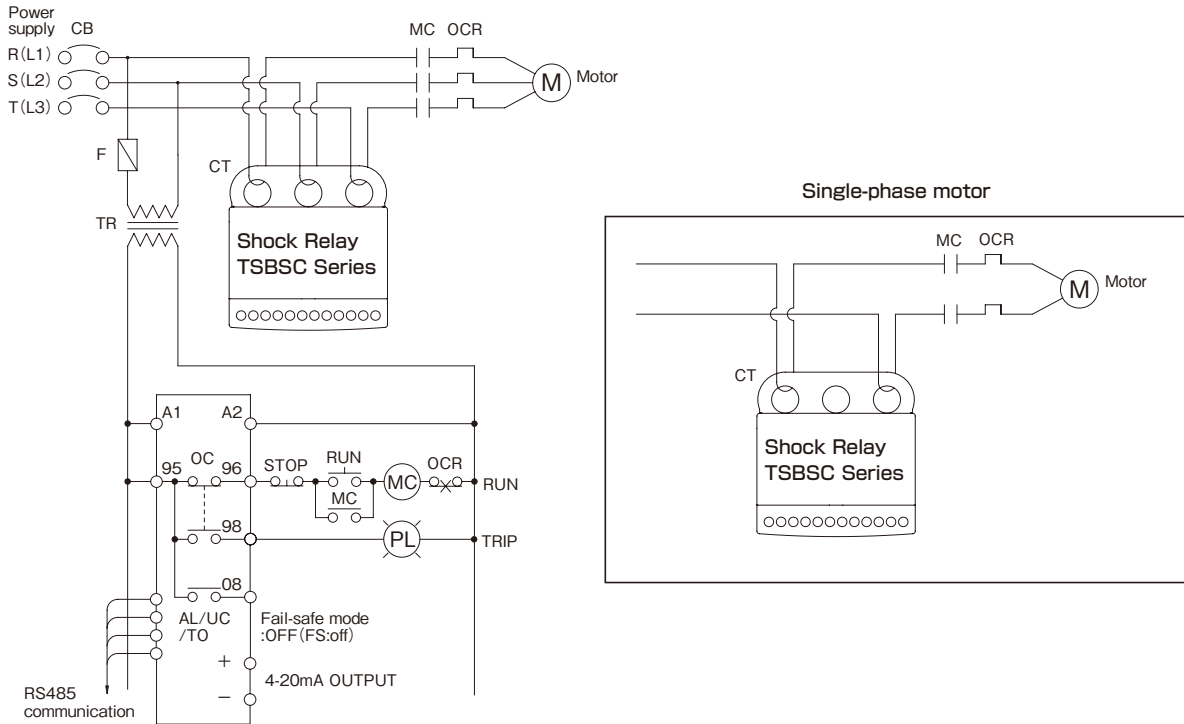

- Note:
1. If necessary, set a transformer (Tr) depending on the voltage on the Shock Relay and electromagnetic contactor (MC). Install an isolating transformer if there is any harmonic noise generating device, such as an inverter.
  2. Output relay is not excited in normal condition and excited in trip condition.
  3. The coil capacity of the MC connected with the output relay of the Shock Relay should be:  
Injection: less than 200VA; Holding: less than 20VA  
As a guide, for TSBSCB60/TSBSCS60, set an auxiliary relay, activate the auxiliary relay with the output relay of the Shock Relay, and open/close the MC with the contact of the auxiliary relay.

## Communication function

### Communication specifications

Item	Details
Transmission standards	RS-485
Max. transmission distance	1200m (Depends on transmission speed)
Transmission system	Half-duplex bidirectional, Modbus protocol
Transmission speed	1.2k to 38.4kbps

### Connection with signal converter

- 1) Prepare a signal converter to use the TSBSC PCON monitoring software .
- 2) Use twisted-pair cables and connect as follows.

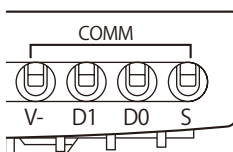

Terminal	Signal	RS485 terminal
V-	GND	GND
D1	Data(B)	Tx+
D0	Data(A)	Tx-
S	Shield	Shield

# Communication function

## PCON monitoring software

Monitoring software for PC is available.

Users can connect a PC and a Shock Relay via a third-party signal converter (RS485/USB).

### Main functions

The following can be done on the PC screen:

- ◇ Set the parameters for the Shock Relay
- ◇ Monitor changes in the motor current
- ◇ View trip history

### Things to prepare

- ① RS485/USB signal converter (commercially available)
- ② USB cable (commercially available; should fit the size of slot ①)
- ③ Twisted-pair cable with shield (commercially available)
- ④ Terminating resistor (120Ω, 1/4W and larger)
- ⑤ TSBSC PCON dedicated monitoring software

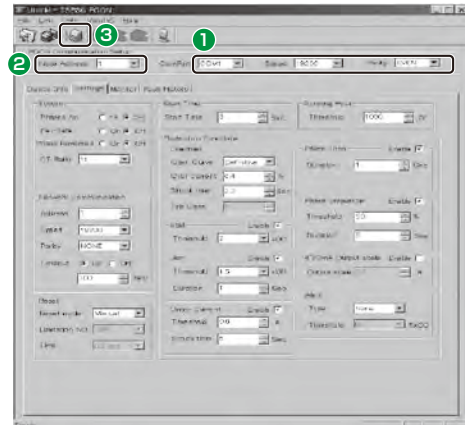

- ① Communication setting at PCON side
- ② Select connected unit
- ③ Start communication

### How to connect

- ① Connect terminals V-, D1, D0, and S with the cable.
- ② Connect the terminating resistor 120Ω between terminating terminal D1 and D0.
- ③ Connect the PC and the signal converter with a USB cable.

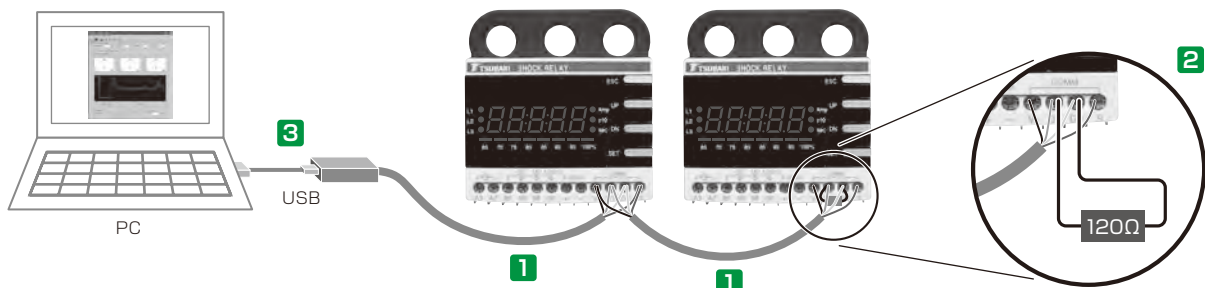

### Set the address of the Shock Relay main unit

Set the address and the communication method for each Shock Relay in advance, before starting communication.

Set the following items by calling up parameter 26 "Communication setting".

Address (1 to 247), Communication speed (1.2 to 38.4kbps), Parity (EVEN, ODD, non), Communication loss time (off, 1 to 999s)

### Set TSBSC PCON software

First, install the monitoring software and signal converter software on the PC.

- ① Click the desktop icon to start up the software. The PCON operating display appears on the screen. On the communication settings for the PCON side, set the communication method to be the same as for the Shock Relay. For [ComPort], select the PC port number in which the USB cable is connected.
- ② Select the address of the connected Shock Relay.
- ③ Click the link icon to begin communication.

Note: If communication with a PLC (sequencer) is necessary without using PC monitoring software, consult Tsubaki.

### Download the PCON monitoring software

PCON can be downloaded from the Tsubaki website.

<http://www.tsubakimoto.jp/products/reference/6/5/>



# Shock Relay SC Series

## Outline dimensions

### All-in-one type main unit TSBSCB06, TSBSCB34, TSBSCB60

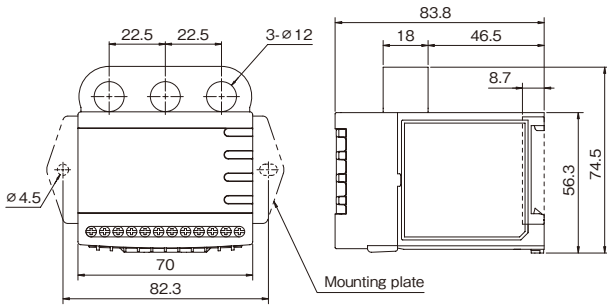

### Panel type main unit TSBSCS06, TSBSCS34, TSBSCS60

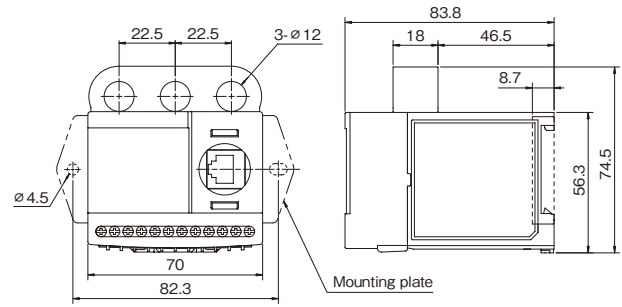

### Panel unit (for panel type) TSBSCD

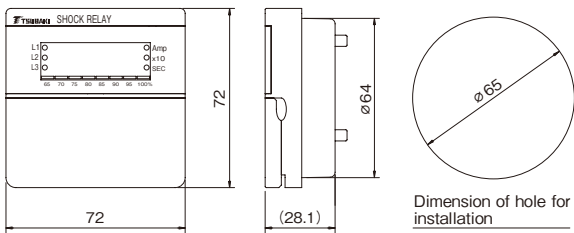

### Cable (for panel type) TSBSCC05, TSBSCC10, TSBSCC15, TSBSCC20, TSBSCC30

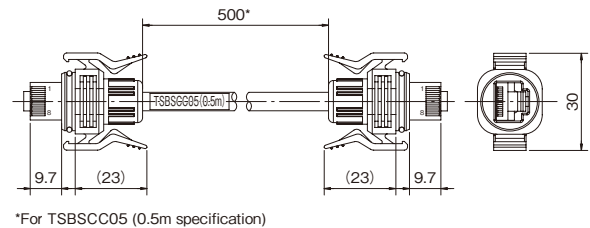

### External CT TSB3CTC100, TSB3CTC200, TSB3CTC300

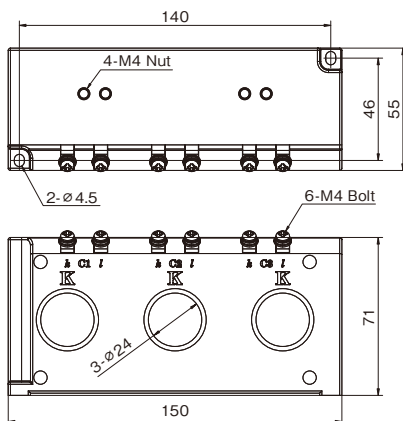

Connect C1 to phase U, C2 to phase V, and C3 to phase W.

# Shock Relay ED Series

## Features

- Digitally displays motor current and set values
- Economically priced
- CT included in one compact unit
- Works with inverter\*  
Current can be precisely detected when inverter is operating between 20 to 200 Hz.
- Choose between self-holding or automatic reset for the output relay
- CE marking
- UL/cUL certification
- CCC certification

\* To prevent unnecessary operation of the Shock Relay due to the increase in current during acceleration/deceleration, accelerate or decelerate slowly or allow a margin in the preset current.

## CT all-in-one model

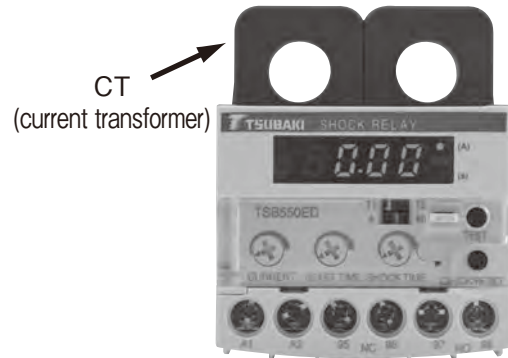

TSB020ED TSB220ED  
TSB075ED TSB550ED

## Standard specifications

Model no.				TSB020ED	TSB075ED	TSB220ED	TSB550ED	
Motor	Applicable motors*1	200V class	DIP switch to select no. of wires passing through CT*4	T2	0.1kW	0.4kW	1.5kW	3.7kW
				T1	0.2kW	0.75kW	2.2kW	5.5kW
	400V class	DIP switch to select no. of wires passing through CT*4	T2	0.1, 0.2kW	—	2.2, 3.7kW	7.5kW	
			T1	0.4, 0.75kW	1.5kW	5.5kW	11kW	
Frequency of detected current				20 to 200Hz				
Maximum motor circuit voltage				AC600V 50/60Hz				
Operating power supply voltage				24 to 240VAC ±10%, 50/60Hz				
Protection functions	Overload	Current setting range*3	DIP switch to select no. of wires passing through CT	T2	0.20 to 1.20A (0.01A increments)	1.20 to 3.20A (0.02A increments)	3.00 to 10.0A (0.1A increments)	6.00 to 26.0A (0.2A increments)
				T1	0.40 to 2.40A (0.02A increments)	1.80 to 5.80A (0.04A increments)	4.00 to 14.0A (0.1A increments)	9.00 to 34.0A (0.25A increments)*2
	Start time*3				0.2 to 10.0s (0.2s increments)			
	Shock time*3				0.2 to 5.0s (0.2s increments)			
Accuracy	Current detection accuracy			±5% ±1 digit or less (except when combined with the inverter, ±10% ±1 digit or less)				
	Temporal accuracy			±5% ±1 digit or less				
Locked rotor start				It will trip if the set current value exceeds 200% when starting, after the set start time +0.2s has elapsed				
Rated load				3A, 250VAC (cosφ=1)				
Minimum allowable load				DC24V, 4mA				
Life				80,000 activations at rated load				
Contact arrangement				1a1b				
Operation				Energization/normal operation: no excitation; Trip: excitation				
Output relay	Reset	DIP switch for selecting trip reset		A	After returning to normal current value, automatically resets in 1 sec.			
				M	Can be manually reset by pressing the "RESET" button			
Withstand voltage	Between housing-circuit			DC500V, 10MΩ				
	Between housing-circuit			2000VAC 60Hz: 1 minute				
	Between relay contact electrodes			1000VAC 60Hz: 1 minute				
Usage environment	Location			Indoors, where it will not get wet				
	Ambient temperature			-20 to +60°C				
	Ambient humidity			30 to 85% RH (no condensation)				
	Altitude			2000m or less				
Power consumption				2.0W or less				
Mass				0.25kg or less				

\*1. The applicable motors are just a rough indication for reference. Make your selection based upon actual electrical current value. Select by electrical current value for single-phase motors as well.

\*2. Set values 10A and higher are displayed as follows due to the maximum number of display digits. 10.0A→10.2A→10.5A→10.7A→11.0A

\*3. A ±1 digit error can occur with the current and the set time in the range indicated.

\*4. Be sure to make one turn when selecting T1 and two turns when selecting T2.

# Shock Relay ED Series

## Part names and functions

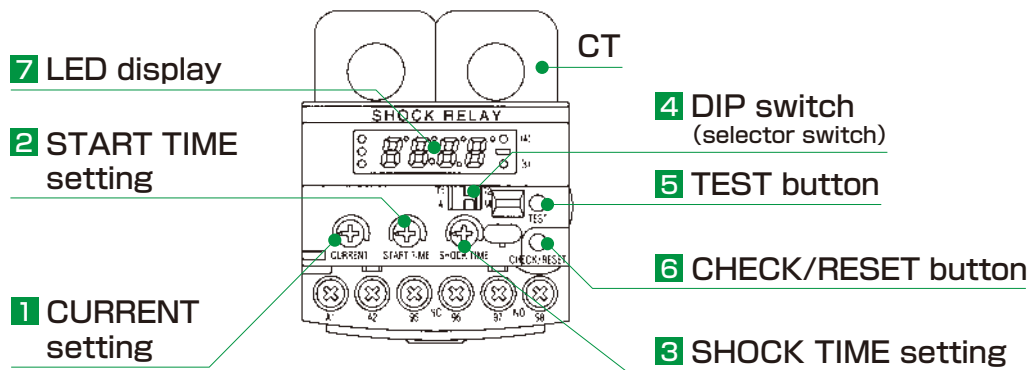

Note: Use a micro screwdriver when changing each of the settings. Do not use a large screwdriver since it may cause damage.

### 1 Current setting (CURRENT)

Sets current at the value at which trip occurs.

### 2 Start time setting (START TIME)

Sets start time (start-up compensation time). When the motor starts, there is a possibility that the motor current will exceed the set current value, but during the start time period it will not trip.

### 3 Shock time setting (SHOCK TIME)

Sets shock time (output delay time). When the motor current exceeds the set current value, the count begins, and when shock time has elapsed, it will trip.

### 4 DIP switch (selector switch)

Setting	Purpose	<input type="checkbox"/>		<input checked="" type="checkbox"/>	
No. of motor wires passing through CT T1/ T2	Current value set range selection	T1	No. of passes through the CT: 1	T2	No. of passes through the CT: 2
Trip reset A / M	Output relay reset selection	A	Automatically returns from the trip state a second after current value returns to below the set current value.	M	Trip state is maintained until the check/reset button is pressed. It then resets.

### 5 TEST button (TEST)

While the LED is displaying current value, pressing the TEST button will carry out an operation test.

### 6 CHECK/RESET button (CHECK/RESET)

During normal operation:

By pressing the CHECK/RESET button while the LED is displaying current value, the display switches to the setting screen.

During trip:

When the CHECK/RESET button is pressed, trip is cleared and the display switches to the current value.

During set-up:

While the LED is showing the setting screen, pressing the CHECK/RESET button will switch the display between current setting, start time setting, shock time settings, and current value, in this order.

### 7 LED display

The LED to the left of (A) will light up when current value and current set-up are displayed. (A = ampere)

The LED to the left of (s) will light up when start time set-up and shock time set-up are displayed. (s = seconds)

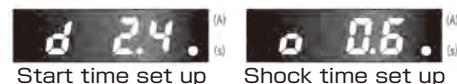
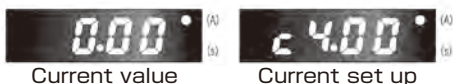

## Comparison with meter relays (analog)

The ED Series is also ideal for applications that use a meter relay (analog). Here are features not available with meter relays.

- Start time (start-up compensation) function
- Shock time (output delay) function
- Compact design, includes CT
- Works with inverter driving
- Choose between self-holding or automatic reset for the output relay
- Includes test function
- Detects locked rotor start



ED Series



Meter relay (analog type)

## Operating mode

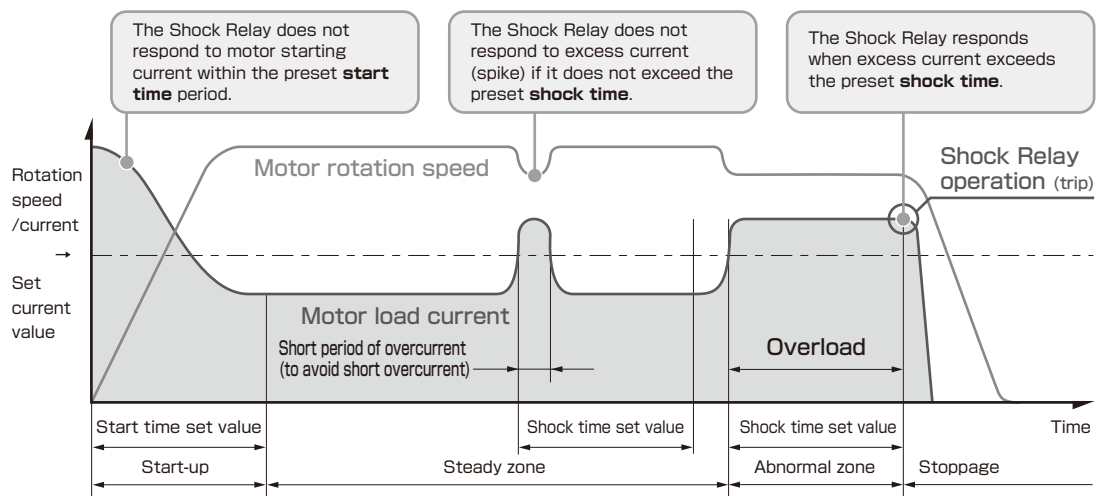

## Outline dimensions

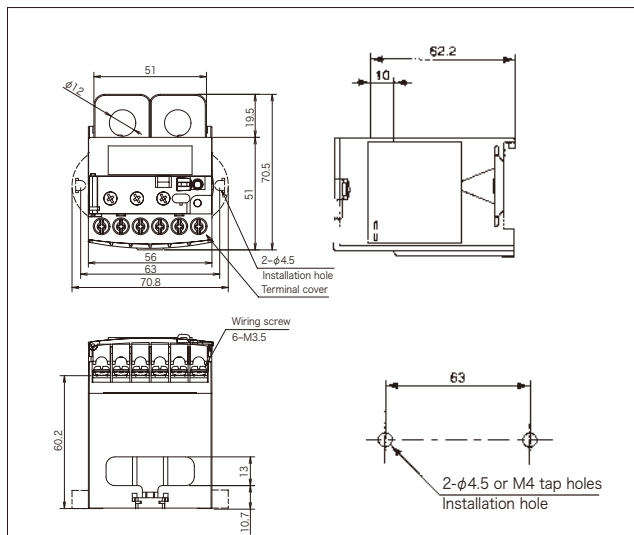

## Basic connection diagram

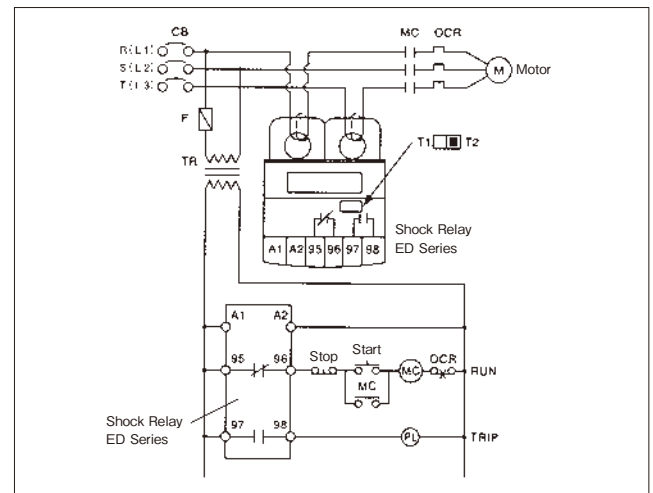

## Model

# TSB020ED

Shock Relay

Maximum applicable motor capacity (200V class)  
 020...0.2kW 075...0.75kW  
 220...2.2kW 550...5.5kW

ED Series



# Shock Relay 150 Series

## Features

- Analog meter
- Self-holding type
- Special MTO models and optional specifications are available

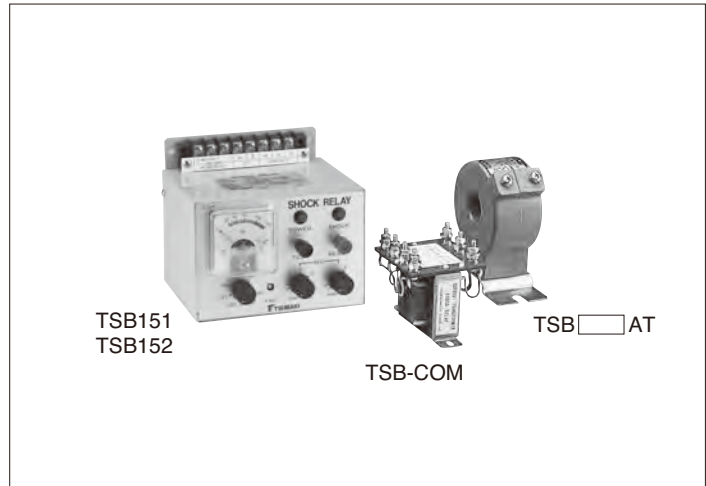

## Standard specifications

Function		Model	TSB151-COM	TSB152, TSB [ ] AT*2	
Common	Motor	200V class	0.2 to 3.7kW*1	5.5 to 90kW	
		400V class	0.2 to 3.7kW	5.5 to 90kW	
	Usage environment	Ambient temperature	-10°C to 50°C		
		Relative humidity	45 to 85% RH; no condensation		
		Vibration	5.9m/s <sup>2</sup> or less		
		Altitude	1000m or less		
Atmosphere	No corrosive gas or dust				
Main unit	Main unit model no.		TSB151	TSB152	
	Load current (current setting range)*4		30 to 130% (100%=5mA)	30 to 130% (100%=5A)	
	Current setting accuracy		±10% (full-scale)		
	Time setting range	Start time*4	0.2 to 20s		
		Shock time*4	0.2 to 3s		
	Control power supply voltage		AC100/110V or AC200/220V, 50/60Hz ±10%		
	Max. motor circuit voltage		AC600V, 50/60Hz		
	Current detecting system		1-phase CT system		
	Output relay	Self-holding	Self-holding available		
		Normal state	Output relay not excited		
		Abnormal state	Output relay excited		
		Contact capacity	1c contact, AC250V 0.2A (inductive load cosφ=0.4)		
	Output relay life	Min. applicable load*3	DC24V, 4mA		
		Mechanical	10,000,000 activations		
		Electric	100,000 activations		
	Test function		Included		
	Withstand voltage	Between circuit-housing	AC1500V, 60Hz, 1 minute (power supply circuit and contact circuit)		
Between contacts		AC700V, 60Hz, 1 minute			
Between circuits		AC1500V, 60Hz, 1 minute (power supply circuit and contact circuit)			
Mass		1.0kg	1.2kg		
Power consumption		1.2VA			
External CT	Accessory external CT model		TSB-COM	TSB [ ] AT ( [ ] ...Rated input current value)	
	Rated input current		0.75A, 1.5A, 1.75A, 2.0A, 2.5A, 3.3A, 4.0A, 5.3A, 7.0A, 9.0A, 10.0A, 16.0A	100A, 120A, 150A, 200A, 250A, 300A	
	Rated output current		5mA	5A	
	Rated load		0.5VA	5VA	
	Mass		0.5kg	0.6kg	

Notes: \*1. If the TSB-COM-A (small-capacity CT) is used, a motor of 0.1kW or less can be used.

\*2. TSB152 and TSB [ ] AT (external CT) have different model numbers.

\*3. When directly inputting output relay contact into the programmable controller (PLC), be aware that a minute electric current can cause contact failure. Therefore, before inputting the output relay contact into the PLC, it is recommended that you drive the relay coil for a minute current via the relay signal.

\*4. Current and time setting ranges are settable ranges, not the upper and lower levels of setting volume.

## Part names and functions

### % Display meter

The meter displays the percentage of the motor current in operation vs. the motor rated current. (The rated current here is based on "Motor rated current" in the CT selection table on page 28.)

### LOAD CURRENT knob

Load current can be set to stop the motor at the desired level when overload occurs. When the motor current exceeds the preset current value (continues to exceed the preset shock time), the Shock Relay activates and stops the motor.

### % Adjust knob

If the input from the CT is 5mA (TSB151) or 5A (TSB152), the meter can be modified in the 95 to 130% range. Also, after adjusting the % adjuster, the meter scale indicator and load current set scale are the same.

### START TIME knob

To prevent the Shock Relay from operating due to the motor start-up current, set the start time a little bit longer than the time the motor settles into the steady zone.

### Terminals

All terminals are located on the upper portion of the Shock Relay, making wiring easy.

### POWER indicator

Lights up when the Shock Relay is turned on.

### Activation indicator

Lights up when the Shock Relay is operating.

### TEST button

Shock Relay operation can be tested stand-alone or during motor operation.

(When testing the Shock Relay, continue to press and hold the TEST button) longer than the set start time or shock time, whichever is longer.

### RESET button

After the Shock Relay activates, the RESET button is used to cancel the self-holding of the output contact.

### SHOCK TIME knob

Shock time is the amount of time set until the Shock Relay activates when overload occurs. Within the set time, the Shock Relay will not activate, even if it is overloaded.

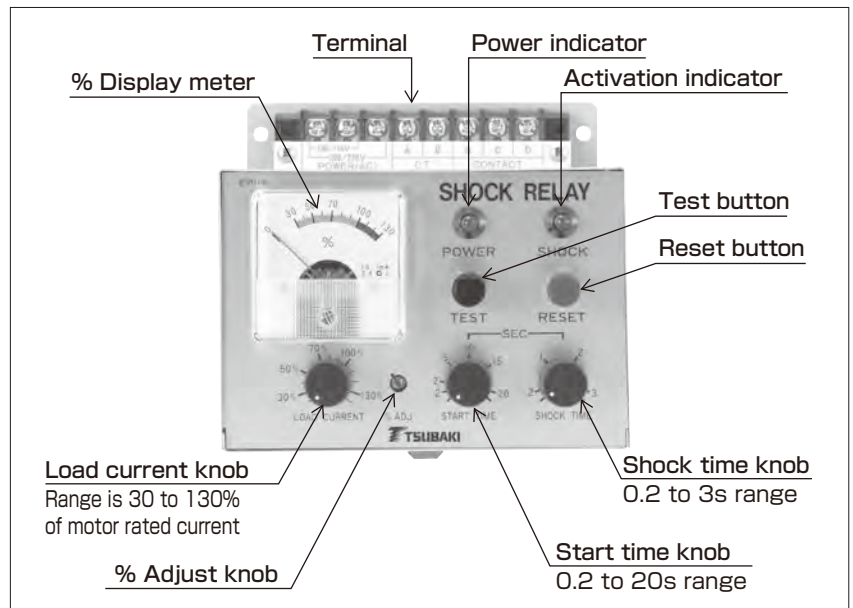

## Operating mode

### Overload operating mode

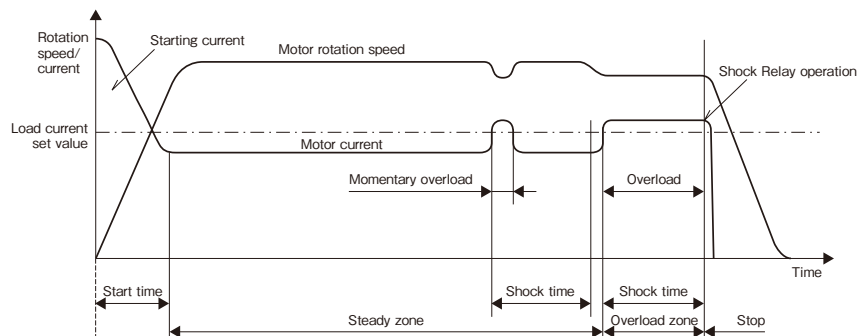

### Light-load operating mode

TSB151W, 152W

(Lower/upper limit detector specifications)

Note: Because there is only one output relay, it is not possible to distinguish between overload operation and light-load operation.

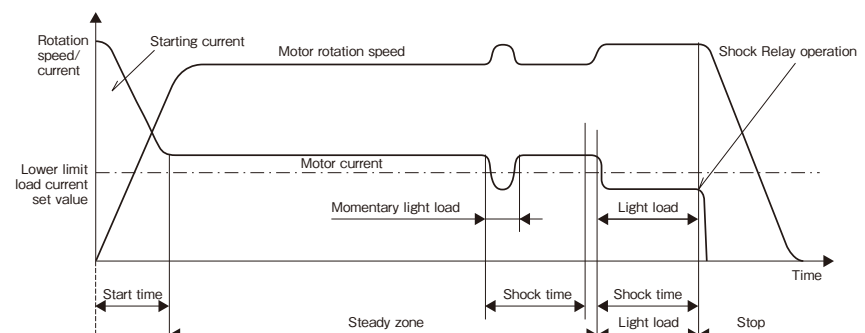

# Shock Relay 150 Series

## Outline dimensions

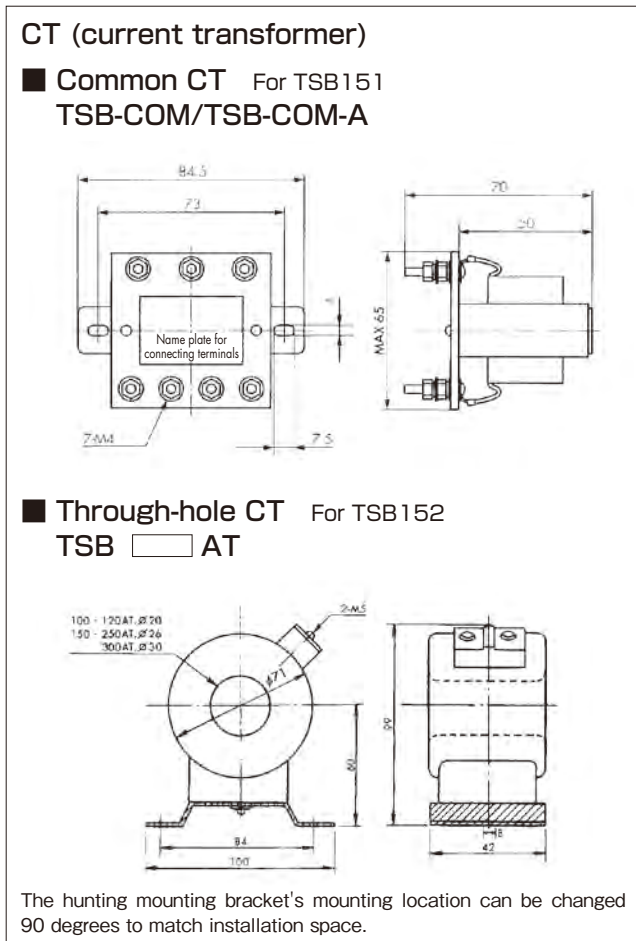
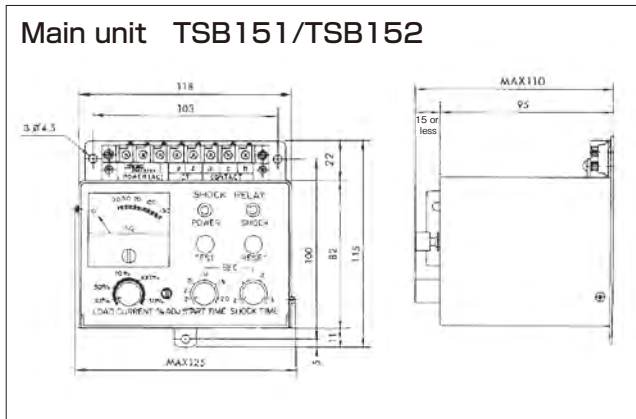

## Model

■ For motors 3.7kW or smaller

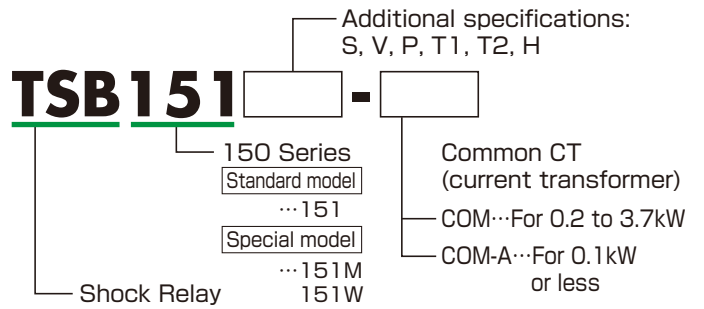

■ For motors 5.5kW or larger

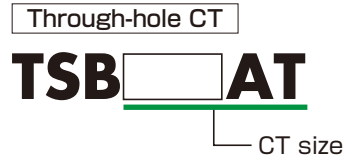
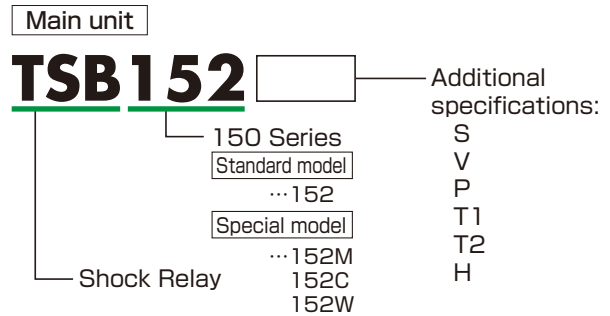

## Standard model and special models with optional specifications

Model	Optional specifications	Subtropical spec.	Control power supply voltage modification	Panel mounted	Start time modification	Shock time modification	Auto-reset
		S	V	P	T1	T2	H
Standard	151/152	○	○	○	○	○	○
Impact load detection	151M/152M	○	○	○	○	○	○
1A input (motor capacity is not necessary to consider)	152C	○	○	○	○	○	○
Upper/lower limit detection	151W	○	○	○	○	○	○
	152W	○	○	○	○	○	○

Notes: 1. Refer to page 10 for detailed specifications  
2. For optional specifications V, specify control power source  
3. For optional specifications T1 and T2, indicate the start time and shock time modification time.

◎ : Multiple specifications available

## CT (current transformer)

### Common CT: for motors 3.7kW or smaller

- TSB-COM (standard) can be used with 0.2 to 3.7kW motors.
- TSB-COM-A (small capacity) can be used with motors up to and including 0.1kW.

### TSB-COM (standard type)

Motors (kW)	Power supply: AC200/220V			Power supply: AC400/440V		
	Motor rated current (A)	Connecting terminal	Shock terminal	Motor rated current (A)	Connecting terminal	Shock terminal
0.2	1.75	K-L <sub>2</sub>	k-l <sub>1</sub>	0.75	K-L <sub>2</sub>	ℓ <sub>1</sub> -ℓ <sub>2</sub>
0.4	2.5	K-L <sub>2</sub>	k-l <sub>2</sub>	1.5	K-L <sub>2</sub>	ℓ <sub>2</sub> -ℓ <sub>3</sub>
0.75	4.0	K-L <sub>2</sub>	k-l <sub>3</sub>	2.0	L <sub>1</sub> -L <sub>2</sub>	ℓ <sub>2</sub> -ℓ <sub>3</sub>
1.5	7.0	K-L <sub>1</sub>	k-l <sub>1</sub>	3.3	L <sub>1</sub> -L <sub>2</sub>	k-l <sub>2</sub>
2.2	10.0	K-L <sub>1</sub>	k-l <sub>2</sub>	5.3	L <sub>1</sub> -L <sub>2</sub>	k-l <sub>3</sub>
3.7	16.0	K-L <sub>1</sub>	k-l <sub>3</sub>	9.0	K-L <sub>1</sub>	ℓ <sub>1</sub> -ℓ <sub>3</sub>

Note: Common CT motor side L<sub>1</sub>-L<sub>2</sub> or Shock Relay side ℓ<sub>1</sub>-ℓ<sub>2</sub> can be combined with a 1A output CT.

### TSB-COM-A (small-capacity type)

Motor rated current (A)	Connecting terminal	
	Motor side	Shock Relay side
0.15	K-L <sub>2</sub>	k-l <sub>1</sub>
0.25	K-L <sub>2</sub>	k-l <sub>2</sub>
0.4	K-L <sub>2</sub>	k-l <sub>3</sub>
0.6	K-L <sub>1</sub>	k-l <sub>1</sub>
1.0	K-L <sub>1</sub>	k-l <sub>2</sub>
1.6	K-L <sub>1</sub>	k-l <sub>3</sub>

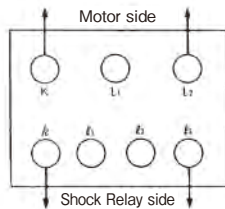

Note: Select by current value.

### Through-type CT for motors 5.5kW or larger

- Select a CT size applicable to motor capacity.

Motor (kW)	Power supply: AC200/220V			Power supply: AC400/440V		
	Motor rated current (A)	CT size	No. of wires passing through CT (I)	Motor rated current (A)	CT size	No. of wires passing through CT (I)
5.5	25	100AT	4	14	100AT	7
7.5	30	120AT	4	20	100AT	5
11	50	100AT	2	25	100AT	4
15	60	120AT	2	30	120AT	4
19	75	150AT	2	37	150AT	4
22	100	100AT	1	50	100AT	2
30	120	120AT	1	60	120AT	2
37	150	150AT	1	75	150AT	2
45	170	200AT	1	85	100AT	1
55	200	200AT	1	100	100AT	1
75	250	250AT	1	130	150AT	1
90	300	300AT	1	150	150AT	1

For single-phase motors or motor capacities not on the selection chart, use the following calculation to make your selection:

$$\text{CT size} \geq \text{Motor rated current} \times \text{Number of wire(s) passing through CT}$$

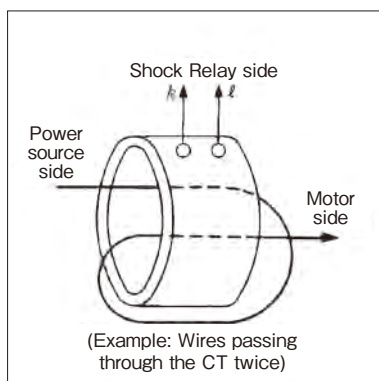

## Basic connection diagram

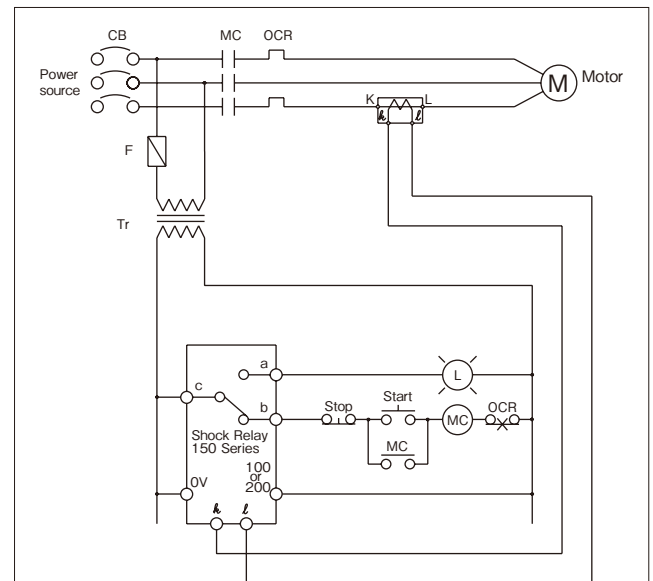

Notes:

1. If the voltage of the main circuit exceeds 220VAC, install a step-down transformer Tr. As well, do not improperly wire the power source wires (AC100V or AC200V).
2. If the CT's secondary side is left open while the primary side is energized, it will cause damage to the CT. When the Shock Relay is not connected, short-circuit the CT's secondary side.
3. The coil capacity of the electromagnetic contactor MC which the TSB150 output contact opens and closes should be less than 200VA when injecting, and less than 20VA when holding.

## Special models and optional specifications

### TSB151P, TSB152P (panel mounted type) outline dimensions

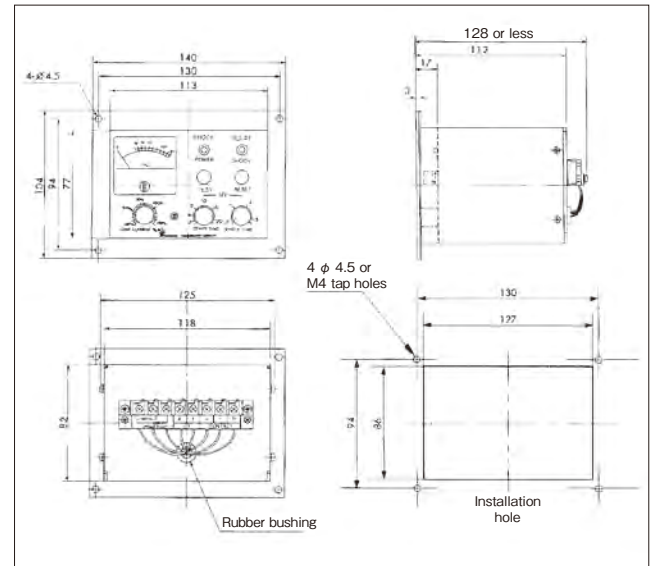

### Notes on CT (current transformer) selection

The load current meter of the Shock Relay shows 100% when the motor rated current is as shown in the chart. When the actual motor rated current value is not on the chart, use a through-hole CT or common CT for which the motor rated current is within the 80% to 100% range of the Shock Relay load current.



# Shock Relay SB Series

## Features

- Choose between self-holding or automatic reset for the output relay
- Economically priced
- Broad current setting range
- High repeating accuracy
- Includes TEST/RESET buttons
- All-in-one unit with CT (current transformer)
- CE marking
- DIN rail (35 mm) mountable
- Can be used with a single-phase motor
- UL/cUL certification
- CCC certification

### CT all-in-one model

CT  
(current transformer)



TSBSB05  
TSBSB10  
TSBSB30  
TSBSB60

### CT externally mounted model

External CT  
(current transformer)

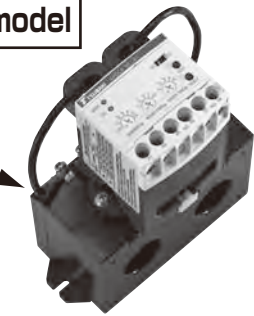

TSBSB100(TSBSB05+TSB2CT100)  
TSBSB200(TSBSB05+TSB2CT200)  
TSBSB300(TSBSB05+TSB2CT300)

## Standard specifications

Model no.		TSBSB05	TSBSB10	TSBSB30	TSBSB60	TSBSB100	TSBSB200	TSBSB300
Current setting range*1		0.5 to 6A	1 to 12A	3 to 30A	5 to 60A	10 to 100A	20 to 200A	30 to 300A
Applicable motor capacity	200V class	0.1 to 0.75kW	1.5 to 2.2kW	3.7 to 5.5kW	7.5 to 11kW	15 to 18.5kW	22 to 37kW	45 to 75kW
	400V class	0.2 to 2.2kW	3.7kW	5.5 to 11kW	15 to 22kW	30 to 45kW	55 to 90kW	110 to 132kW
Time setting range*1	Start time	0.20 to 10s*2						
	Shock time	0.2 to 5s*2						
Current setting accuracy		±10% (full scale)						
Operating power source		AC100 to 240V AC / DC±10%, 50/60Hz						
Maximum motor circuit voltage		AC600V, 50/60Hz						
Current detection system		2-phase CT system						
Display		MON lamp on during normal monitoring OC lamp on during overcurrent monitoring						
Output relay	Contact arrangement	1a1b						
	Contact rating	3A AC250V cos φ = 1						
	Recommended current (during frequent operation)	0.2 A or less AC250V cos φ = 0.4						
	Min. applicable load*3	DC10V, 10mA						
	Operation selection	DIP switch SS: Excitation during normal operation, self-holding after tripping SA: Excitation during abnormal operation, auto reset after tripping						
Usage environment	Life	80,000 activations at contact rating load						
	Operating temperature range	-20 to 60°C						
	Storage temperature range	-30 to 70°C						
	Humidity	45 to 85% RH; no condensation						
	Altitude	2,000 m or less						
Atmosphere	No dust or corrosive gas; To be installed inside control panel with pollution degree 3 or under							
	Vibration	5.9m/s <sup>2</sup> or less						
Insulation resistance	Between circuit-housing	10 MΩ or higher (DC 500V megger)						
Withstand voltage	Between circuit-housing	AC 2000V, 60 Hz, 1 min.						
	Between contacts	AC 1000V, 60 Hz, 1 min.						
	Between circuit	AC 2000V, 60 Hz, 1 min.						
Protective structure		IP20						
Material	Housing	Upper housing: PA6; lower housing: PA66						
	Terminal cover	PA6						
Power consumption		2W or less						
Installation		Mounted on 35 mm DIN rail or accessory mounting plate						
Mass	Main unit (external CT only)	0.2kg (0.5kg)						

Notes  
\*1: Current and time setting ranges are settable ranges, not the upper and lower levels of setting volume.  
\*2: Although the minimum value on the display is 1s, values smaller than 1s can be set with the dial.  
\*3: When directly inputting output relay contact into the programmable controller (PLC), be aware that a minute electric current can cause contact failure. Therefore, before inputting the output relay contact into the PLC, it is recommended that you drive the relay coil for a minute current via the relay signal.

## Part names and functions

### LOAD CURRENT setting

Load current can be set to stop the motor at the desired level when overload occurs. When the motor current exceeds the preset current value (continues to exceed the preset shock time), the Shock Relay activates and stops the motor.

### START TIME setting

To prevent the Shock Relay from operating due to the motor start-up current, set the start time a little bit longer than the time the motor settles into the steady zone.

### TEST button

Shock Relay operation can be tested stand-alone or during motor operation.

(When testing the Shock Relay, continue to press and hold the TEST button longer than the set start time or shock time, whichever is longer.)

### RESET button

After the Shock Relay activates, the RESET button is used to cancel the self-holding of the output contact.

### SHOCK TIME setting

Shock time is the amount of time set until the Shock Relay activates when overload occurs. Within the set time, the Shock Relay will not activate, even if it is overloaded.

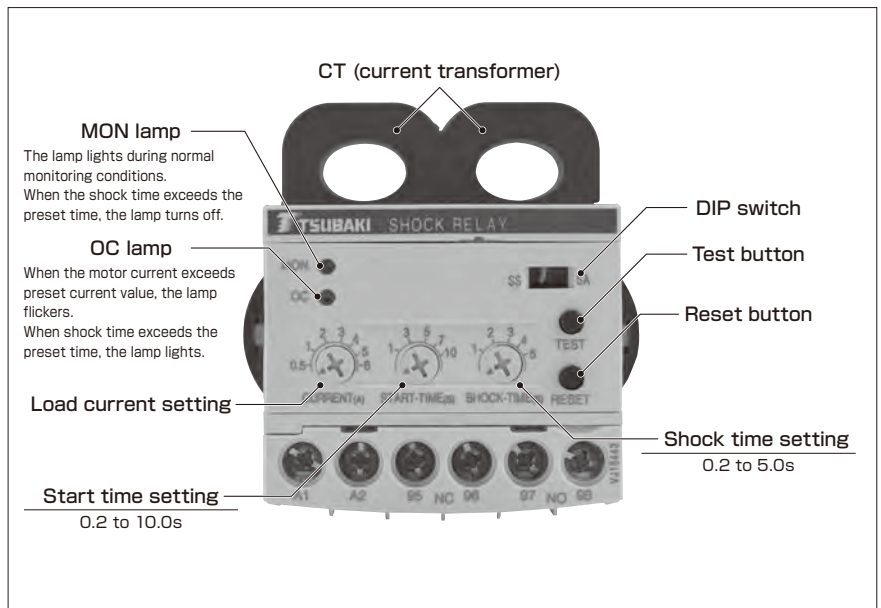

## Operating mode

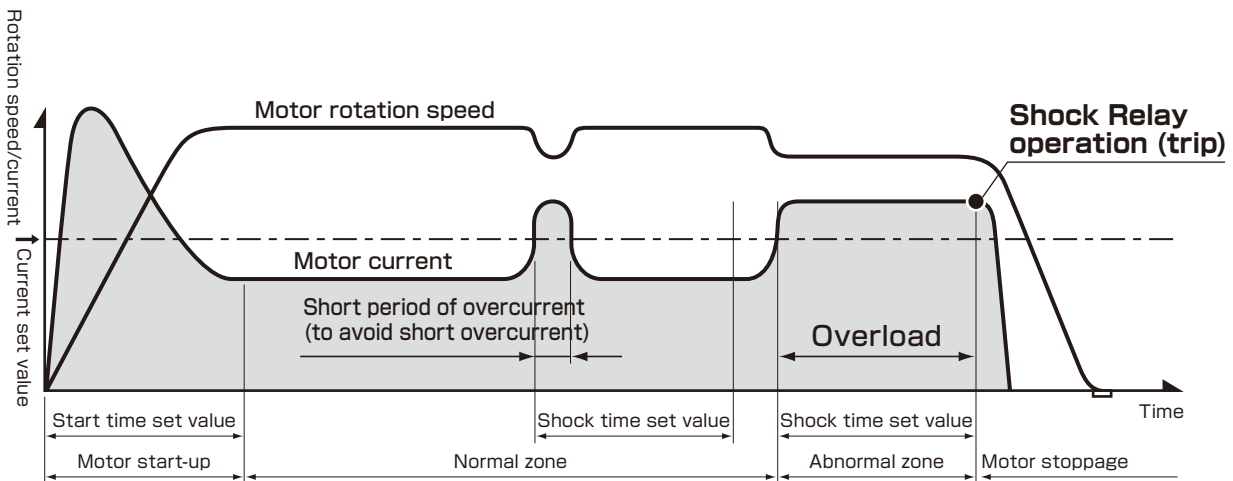

## Model

**TSB SB 05**

Shock Relay      SB Series      Size

# Shock Relay SB Series

## Outline dimensions

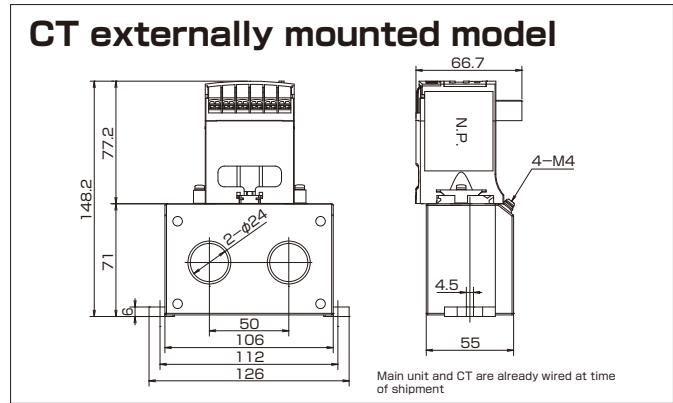
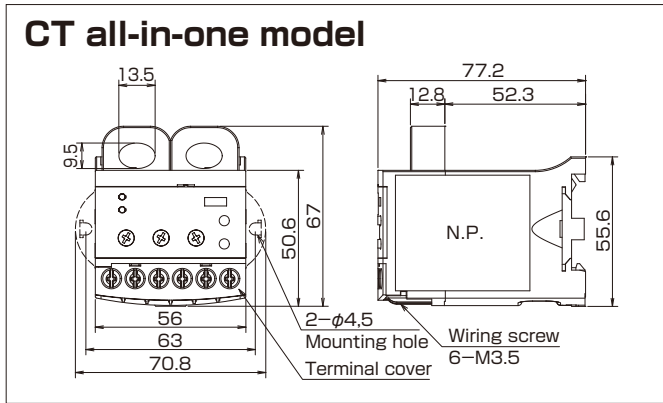

## Basic connection diagram

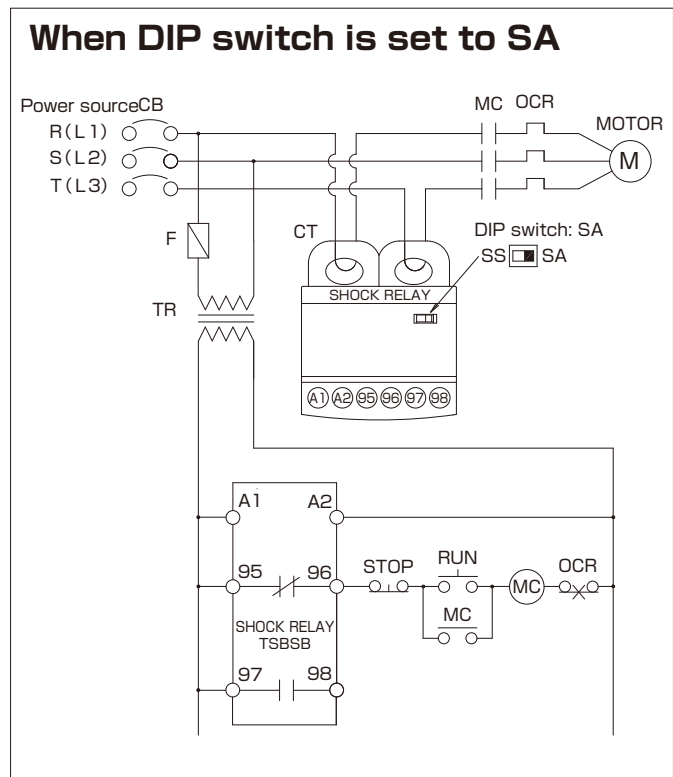
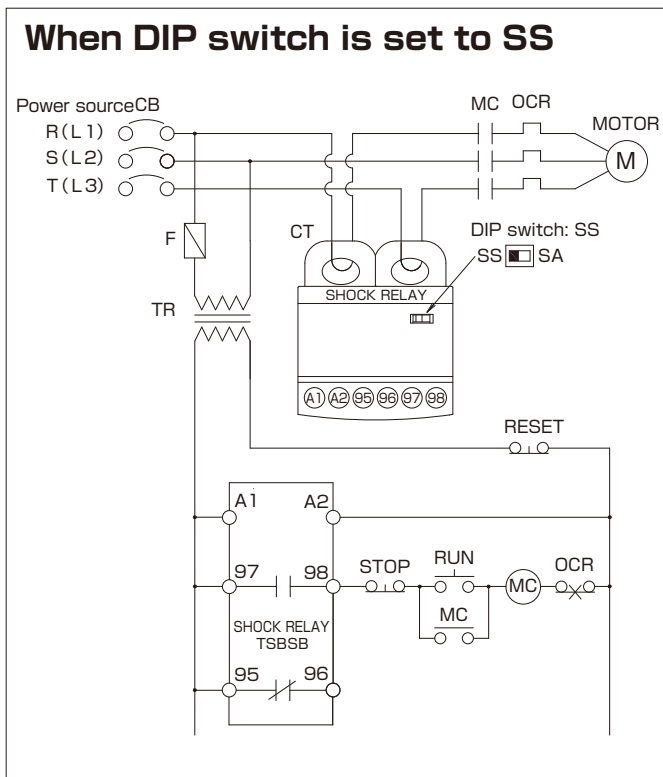

## Number of wire(s) that pass through the CT

Depending on motor capacity, use the chart on the right to select the applicable Shock Relay model and number of wire(s) to pass through the CT.

In order to increase the current setting accuracy, the number of wires that pass through the CT is two times or more for small motor currents.

When the motor load factor is low, increase the number of wires that pass through the CT as necessary.

Furthermore, when the number of the wires that pass through the CT is more than two, it is necessary to convert the current scale value of current volume.

(Ex.) When a wire passes two times through the CT, the value on the current scale should be at half value.

AC 200V class motor			AC 400V class motor		
Capacity (kW)	Shock Relay model no.	No. of wires passing through CT	kW	Shock Relay model no.	No. of wires passing through CT
0.1	TSBSB05	4	—	—	—
0.2	TSBSB05	3	0.2	TSBSB05	4
0.4	TSBSB05	2	0.4	TSBSB05	3
0.75	TSBSB05	1	0.75	TSBSB05	2
1.5	TSBSB10	1	1.5	TSBSB05	1
2.2	TSBSB10	1	2.2	TSBSB05	1
3.7	TSBSB30	1	3.7	TSBSB10	1
5.5	TSBSB30	1	5.5	TSBSB30	1
7.5	TSBSB60	1	7.5	TSBSB30	1
11	TSBSB60	1	11	TSBSB30	1
—	—	—	15	TSBSB60	1
—	—	—	18.5	TSBSB60	1
—	—	—	22	TSBSB60	1

# Shock Relay 50 Series

## Features

- Economically priced
- Automatic reset
- Optional specifications available

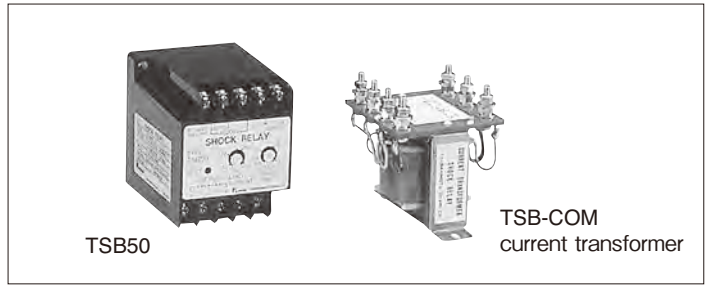

## Standard specifications

Function		Model no.	TSB50-COM
Common	Motor	200V class	0.2 to 3.7kW*1
		400V class	0.2 to 3.7kW
	Usage environment	Ambient temperature	-10°C to 50°C
		Ambient humidity	45 to 85%RH; no condensation
		Vibration	5.9m/s <sup>2</sup> or less
		Altitude	1000m or less
Atmosphere	No corrosive gas or dust		
Main unit	Main unit model no.		TSB50
	Load current (current setting range)*3		50 to 130% (100%=5mA)
	Current setting accuracy		±10% (full-scale)
	Time setting range	Start time	Fixed at 3s
		Shock time	0.3 to 3s
	Control power supply voltage		AC100/110V or AC200/220V, 50/60Hz ±10%
	Max. motor circuit voltage		AC600V, 50/60Hz
	Current detecting system		1-phase CT system
	Output relay	Self-holding	No self-holding (automatic reset)
		Normal state	Output relay is not excited
		Abnormal state	Output relay is excited
		Contact capacity	1s contact, AC250V 0.1A (inductive load cosφ=0.4)
	Output relay life	Min. applicable load*2	DC10V, 10mA
		Mechanical	10,000,000 activations
	Electrical	100,000 activations	
Test function		Not available	
Withstand voltage	Between circuit-housing	AC1500V, 60Hz, 1 minute (power supply circuit and contact circuit)	
	Between contacts	AC500V, 60Hz, 1 minute	
	Between circuits	AC1500V, 60Hz, 1 minute (power supply circuit and contact circuit)	
Mass		0.3kg (not including external CT)	
Power consumption		0.5VA	
Accessory external CT model		TSB COM	
External CT	Rated primary current		0.75A, 1.5A, 1.75A, 2.0A, 2.5A, 3.3A, 4.0A, 5.3A, 7.0A, 9.0A, 10.0A, 16.0A
	Rated secondary current		5mA
	Rated load		0.5VA
	Mass		0.5kg

Notes:

\*1. If the TSB-COM-A (small-capacity CT) is used, a motor of 0.1kW or less can be used.

\*2. When directly inputting output relay contact into the programmable controller (PLC), be aware that a minute electric current can cause contact failure. Therefore, before inputting the output relay contact into the PLC, it is recommended that you drive the relay coil for a minute current via the relay signal.

\*3. Current and time setting ranges are settable ranges, not the upper and lower levels of setting volume.

## Part names and functions

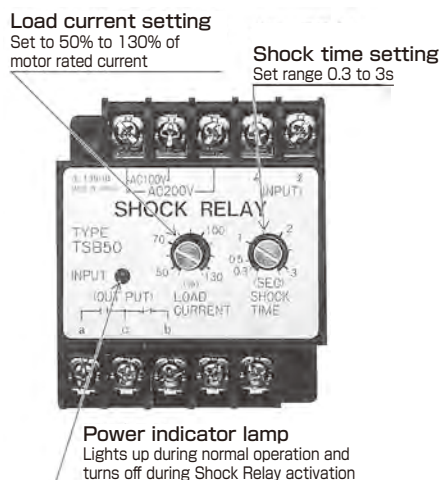

## Operating mode

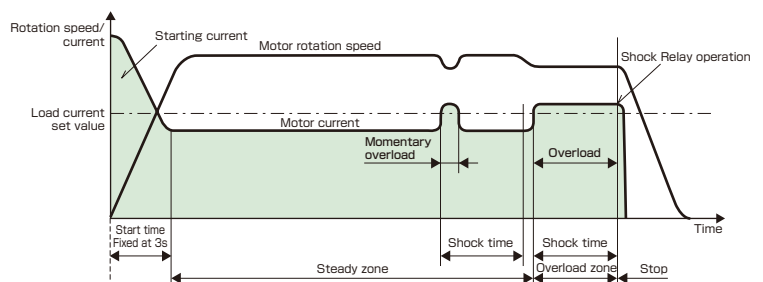



# Shock Relay 50 Series

## Outline dimensions

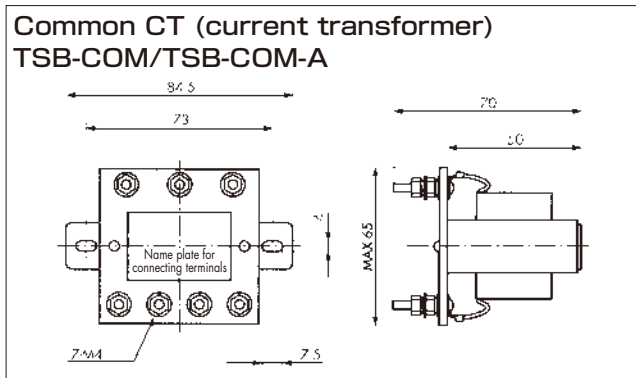
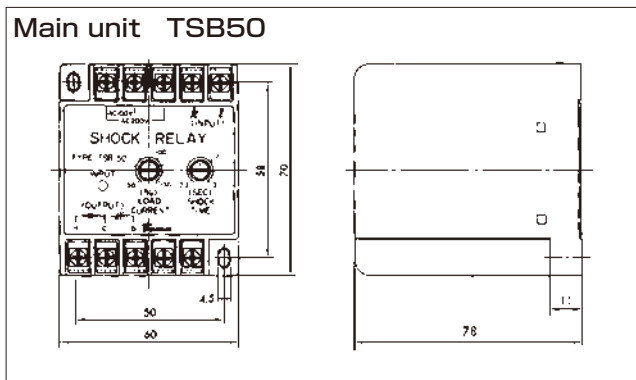

## Model

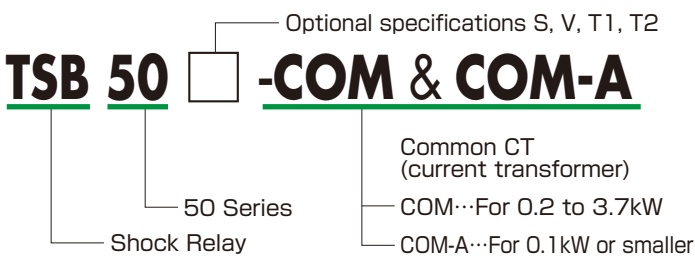

Note: Use the main unit and CT as a set.

## Notes on CT (current transformer) selection

The load current meter of the Shock Relay shows 100% when the motor rated current is as shown in the chart. When the actual motor rated current value is not on the chart, use a through-hole CT or common CT for which the motor rated current is within the 80% to 100% range of the Shock Relay load current.

## Optional specifications

Model	Optional specs.	Subtropical specifications	Control power supply voltage modification	Start time modification	Shock time modification
		S	V	T1	T2
TSB50		○	○	○	○

Notes: 1. Refer to page 10 for detailed specifications  
 2. For optional specifications V, specify operating power supply voltage.  
 3. For optional specifications T1 and T2, indicate the start time and shock time modification time.

○: Multiple specifications available

## Basic connection diagram

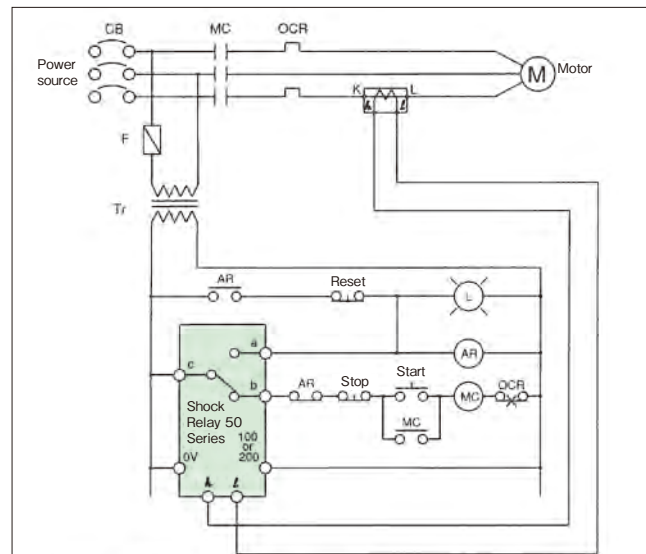

Notes:

- When the main circuit's voltage exceeds 220VAC, install a step down transformer Tr. As well, take care not to make a mistake with the power source (AC100V or AC200V) wiring.
- If the CT's secondary side is left open while the primary side is energized, it will cause damage to the CT.  
When the Shock Relay is not connected, short-circuit the CT's secondary side.
- The coil capacity of the electromagnetic contactor MC which the TSB150 output contact opens and closes should be less than 200VA when injecting, and less than 20VA when holding..

## Common CT (current transformer)

- TSB-COM (standard) can be used with 0.2 to 3.7kW motors.
- TSB-COM-A (small capacity) can be used with motors up to and including 0.1kW.

### TSB-COM (standard type)

Motor (kW)	Power supply: AC200/220V		Power supply: AC400/440V	
	Motor rated current (A)	Connecting terminal	Motor rated current (A)	Connecting terminal
0.2	1.75	K-L <sub>2</sub>	0.75	K-L <sub>2</sub>
0.4	2.5	K-L <sub>2</sub>	1.5	K-L <sub>2</sub>
0.75	4.0	K-L <sub>2</sub>	2.0	L <sub>1</sub> -L <sub>2</sub>
1.5	7.0	K-L <sub>1</sub>	3.3	L <sub>1</sub> -L <sub>2</sub>
2.2	10.0	K-L <sub>1</sub>	5.3	L <sub>1</sub> -L <sub>2</sub>
3.7	16.0	K-L <sub>1</sub>	9.0	K-L <sub>1</sub>

Note: Common CT motor side L<sub>1</sub>-L<sub>2</sub> or Shock Relay side ℓ<sub>1</sub>-ℓ<sub>2</sub> can be combined with a 1A output CT.

### TSB-COM-A (small-capacity type)

Motor rated current (A)	Connecting terminal	
	Motor side	Shock Relay side
0.15	K-L <sub>2</sub>	k-ℓ <sub>1</sub>
0.25	K-L <sub>2</sub>	k-ℓ <sub>2</sub>
0.4	K-L <sub>2</sub>	k-ℓ <sub>3</sub>
0.6	K-L <sub>1</sub>	k-ℓ <sub>1</sub>
1.0	K-L <sub>1</sub>	k-ℓ <sub>2</sub>
1.6	K-L <sub>1</sub>	k-ℓ <sub>3</sub>

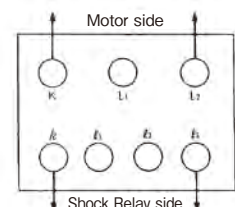

Note: Select by current value.

# SHOCK MONITOR



Features ..... p35

Model reference chart ..... p36

Application examples  
and basic operations of each type

Shock Monitor  
TSM4000 ..... p37

Shock Monitor  
TSM4000 / TSM4000H1 ..... p43

Shock Monitor  
TSM4000H2 ..... p44

Shock Monitor  
TSM4000M1 ..... p43

Shock Monitor  
TSM4000M2 ..... p46

Shock Monitor  
TSM4000M3 ..... p47

Shock Monitor  
TSM4000C1 ..... p48

External connection,  
parameter settings,  
terminal functions ..... p49

# Shock Monitor

## Features

The Shock Monitor is an electricity-monitoring control device that detects minimal load variations by monitoring motor input power.

- **Ideal for monitoring light loads**

For a standard motor there are only minute current variations in the light load zone. For load monitoring of a device used in the light load zone, monitoring electric power variations in the proportional load is ideal.

- **Almost completely unaffected by source voltage variation**

Even with a constant load, if the power supply voltage fluctuates then current will fluctuate largely, thus making accurate load detection impossible. The Shock Monitor monitors electricity so it is almost completely unaffected by voltage fluctuation, making stable load detection possible.

- **Can be used with a wide range of frequencies (5 to 120Hz)**

Can be used with an inverter and a servomotor drive. (The inverter's electronic thermal relay is for burnout protection and is not suitable for device protection.)  
Note: If the power source frequency exceeds 120Hz, such as a servomotor for a machine tool's main spindle, consult Tsubaki.

- **Quick response**

Motor input power is measured every 0.02 seconds. Right after an emergency, the signal is output in a minimum of 0.05 seconds.

- **Records load conditions**

The direct current voltage that is proportionate to motor input power is output, so the load condition can be recorded on the recorder.

TSM4000 Series
-200 to +200% converted into 0 to 10V (basic type)
0 to +200% converted into 0 to 10V (optional)
0 to +200% converted into 4 to 20mA (optional)

- **CE compliancy possible**

For details, contact Tsubaki.

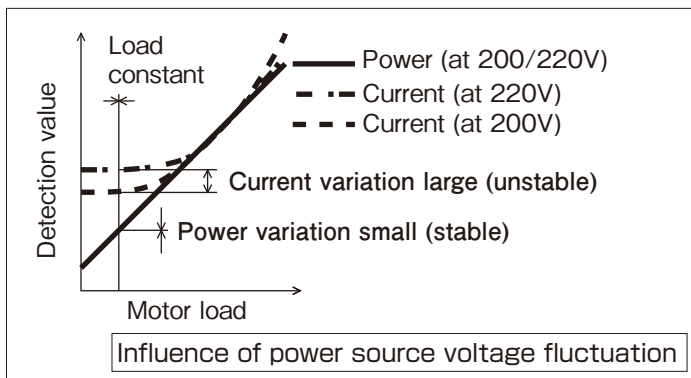
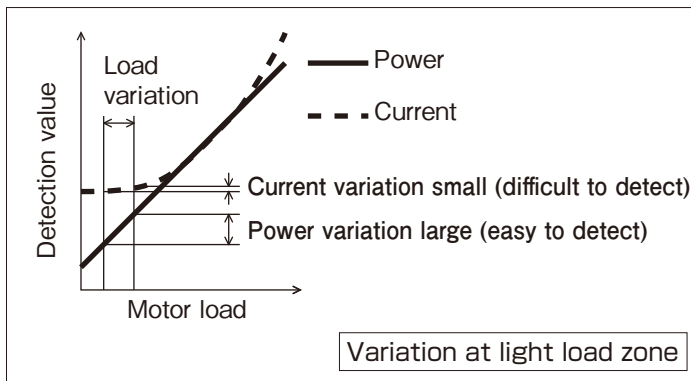

### Example: Power and current variation corresponding to load variation

- (1) Power variation that is proportional to load variation can be seen.
- (2) From the chart below we can see that with a load variation of about 10%, there is almost no change in current, while power makes a significant change.

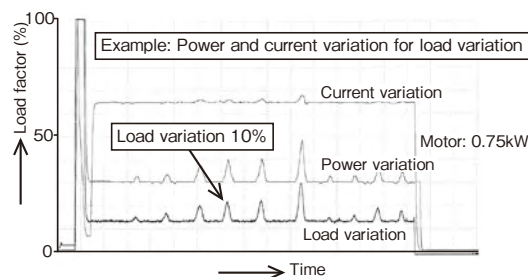

## Model reference chart

Item	Model no.	TSM4000 Basic type*1 *2	TSM4000H1 Economy type*2	TSM4000H2 Load following type	TSM4000M1 Contact detection type	TSM4000M2 Integral power type	TSM4000M3 Processing tool breakage detection type	TSM4000C1 Built-in forward/reverse sequencer type	
Motor	Capacity	0.1 to 110kW							
	Power supply voltage*3	AC200/220V, AC400/440V							
	Frequency	5 to 120Hz							
Control power supply voltage		AC90 to 250V 50/60Hz, DC90 to 250V Nonpolar							
Input	Motor voltage*3	AC250V, MAX							
	Current sensor	DC2.5V							
	Control input	X1, X2, X3, IH, RST	X1, X2, RST	X1, RST	X1, X2, X3, X4, X5			X1, X2	
Output	No. of contacts	3c	2c		3c			2a, 1b, 1c	
	Relay contact output	AC250V, 0.5A (Inductive load $\cos \phi = 0.4$ ) DC30V, 0.4A (inductive load) DC110V, 0.2A (inductive load), Minimum applicable load DC24V, 4mA							
	Output relay life	Mechanical	10,000,000 activations						
		Electrical	100,000 activations						
	Analog output signal	DC0 to 10V							
Settings	Load setting level	Output 1	High1 – 200 to 200%	HIGH1 5 to 200%	HIGH1 1 to 99%	OUT1 1 to 99%	OUT1 0 to 99%	OUT1 1 to 99%	Overload 5 to 200%
		Output 2	High2 – 200 to 200%	HIGH1 5 to 200%		OUT2 1 to 99%	OUT2 5 to 200%		No load 5 to 200%
		Output 3	Low – 99 to 99%	——		OUT3 5 to 200%		OUT3 100 to 30000%	——
	Start time setting range	0.1 to 20.0s							1 to 300s
	Shock time setting range	“MIN” or 0.1 to 10.0s If motor power source frequency is 50Hz or higher, shock time at “MIN” is approximately 50ms.							
Reponse	Set by average number of movements	QUICK (average 1 time), NORMAL (average 5 times), SLOW (average 20 times)				Set by average number of movements	QUICK (average 1 time) NORMAL (average 5 times) SLOW (average 20 times)		
Functions	Inhibit function*4	Manual/auto switching	Auto inhibit		Manual/auto switching			——	
	Relay self-holding	Self-hold/auto reset selectable				Only OUT3 is selectable	Self-hold/auto reset selectable	Sequencer function	
	Detection level changeover	8 steps	4 steps	None	8 steps		4 steps	None	
	Test function	Relay output test							
	Peak-hold function	When the load factor exceeds the preset level (or falls below it), the monitor shows the maximum value within shock time. Only when the relay output is set as self-hold, the monitor will show the highest signal level for a certain amount of time (peak hold).							
Display	% Power display range	– 200 to 200%	0 to 200%						
	Voltage display range	0 to 500V							
	Current display range	0.01 to 999A							
	Frequency display range	5 to 120Hz							
Power consumption		10VA (inrush current 5A within 5ms)							
Mass		1.0kg							
Usage environment	Ambient temperature	0 to 50°C							
	Relative humidity	45 to 85% RH; no condensation							
	Altitude	1000m or less							
	Atmosphere	No corrosive gas or dust							

Note: \*1. Basic type can monitor not only positive (plus) torque but also negative (minus) torque.

\*2. Basic type and economy type can monitor power or torque. (Negative torque cannot be monitored by the economy type.)

In case of torque monitoring, torque is calculated by the monitored power, and displayed. In this case, rated torque (100%) is that at 60Hz.

If the frequency is 20Hz or below, errors become larger due to motor efficiency. In this case, use for power monitoring.

\*3. If the Shock Monitor is used with a AC400/440V motor, the TSM4-PR1 400V class resistor is required.

\*4. A function to stop the power detection of the Shock Monitor. Basic, M1, M2, and M3 types can inhibit manually. During the time the inhibit input terminal and CM are ON within the preset time, or during ON, the load factor will blink at 0% and the Shock Monitor will not detect power. In addition, if the motor voltage sees a frequency change of 4Hz/1s, detection is automatically stopped. (Auto inhibit)

### Warning

When using the Shock Monitor with a human transport device or a lifting/lowering device, install a suitable protection device on that equipment for safety purposes. Otherwise an accident resulting in death, serious injury, or damage to the equipment may occur due to a falling accident.

# Shock Monitor

Quickly detects small load changes

## Shock Monitor TSM4000



### Contributes to visualization in factories (option)

Combining a commercially available touchpanel display and a Shock Monitor having an optional communication function makes it possible to display the current readout of the Shock Monitor and a trend graph of the readout on a remote display. Also, you can change the parameters of the Shock Monitor through remote touchpanel operations.

### Features

#### Safety design

The terminal block is equipped with a cover. This structure prevents dust from entering the main unit.

#### Analog output

0 to 10 V analog output comes standard, enabling action and monitoring according to the load. (0 to 5 V and 4 to 20 mA outputs are optionally available.)

#### Environmentally friendly

The backlight automatically turns off, contributing to energy savings. This product also does not contain any RoHS restricted substances.

#### Improved handleability

The panel-mount design has been standardized to make connection to the terminal block easy when mounting this product on a panel. Also, this product can be mounted on DIN rails.

### Basic operations of TSM4000

#### Overload operating mode

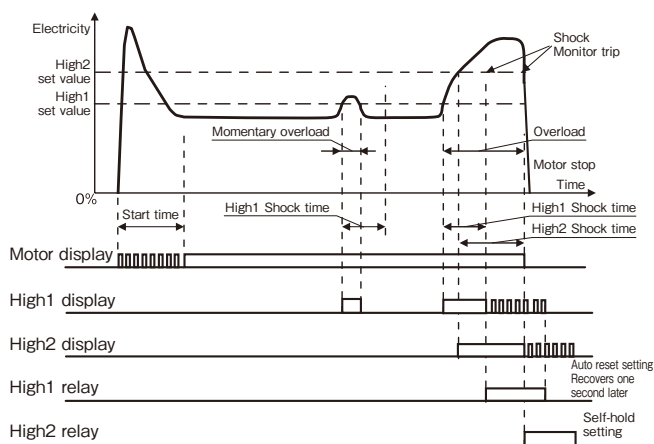

#### Light-load operating mode

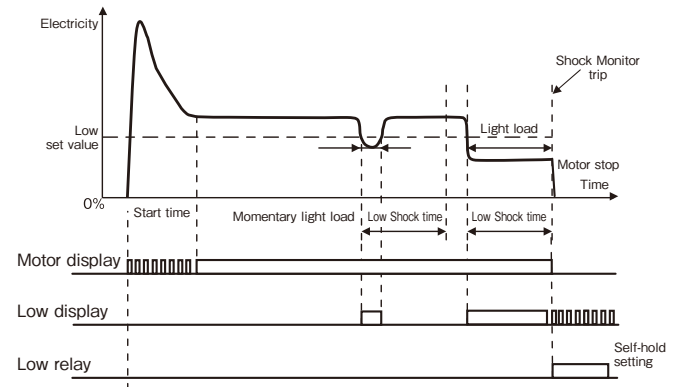

Note: The counting of both the start time and the shock time begins when the motor starts. Therefore, the one set to a longer time is valid.

- 1) The TSM4000 compares the load with the preset overload detection level, and presents an external notification of load abnormality when an overload state (or a light-load state) continues for a certain period of time (the shock time).
- 2) Two upper-limit emergency signals and one lower-limit emergency signal are available and can be used as advance notification signals or motor stop signals.
- 3) To prevent false output due to acceleration, the load detection is canceled for a preset time (the start time) when starting the motor.
- 4) A torque monitoring function (20 to 120 Hz) is available, which is effective when an inverter is used. See Note \*2 on page 36.



## ● Usage examples

### Overload protection for machine tools, detection of drill breakage

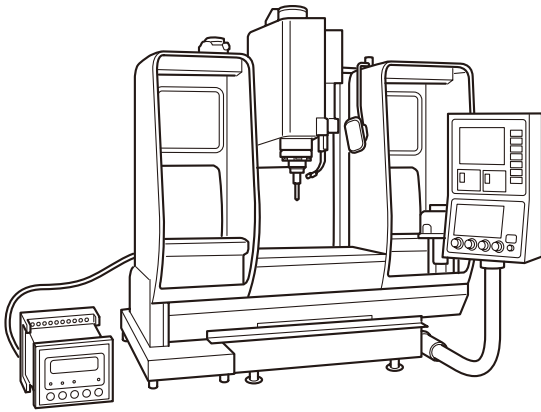

In a drilling process using a machine tool, the Shock Monitor reliably detects not only overload but also any breakage of the drill, preventing defective products from being produced during unattended operation.

Additionally, using a model that calculates integral power values enables detection of wear in the drill with high accuracy. Replacing the drill before breakage can contribute to better productivity.

### Overload protection for suspension/hoisting devices

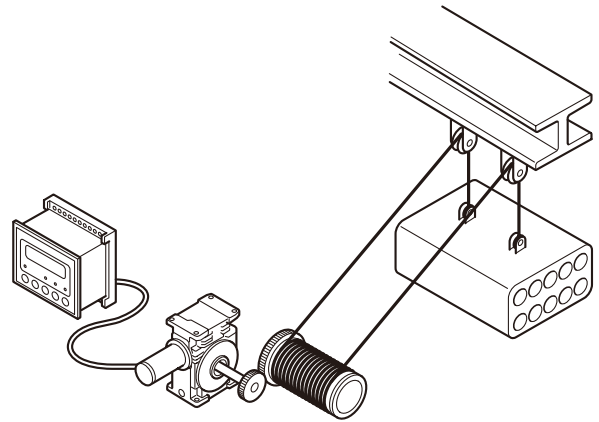

The Shock Monitor can be used with a hoisting device on a staging set or in a factory. When the load on the device exceeds the design load (allowable load), the drive system is stopped automatically to prevent accidents such as dropping.

The power detection method ensures highly accurate load detection even for high-reduction operation using a worm gear reducer in the drive unit.

## ● Application examples of the optional communication function

The optionally available communication function enables the combination of the Shock Monitor and a commercially available touchpanel display unit to be used in the following ways:

Functions available with the display unit

- Displaying of electrical power, current, and voltage data in graph form
- Saving of the above data and transferring the data into memory
- Reading/writing of setting values for a specified parameter

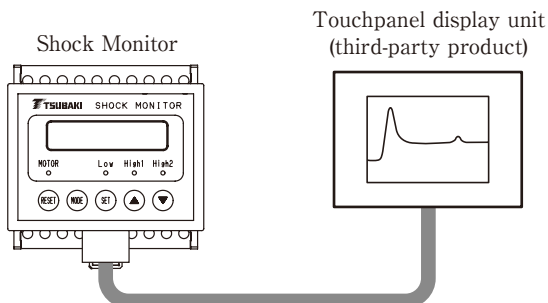

### Communication specifications

Item	Brief specifications
Transmission standard	RS485
Communication method	Half-duplex, bidirectional, Modbus protocol
Transmission speed	Selectable from 2.4, 4.8, 9.6, 19.2, and 38.4kbps

Usage

- The production process can be monitored using real-time displays of power and current waveforms.
- Checking the waveform of abnormal events is effective in preventive measures or making improvements to guard against device damage.

For details, contact Tsubaki.

# Shock Monitor

## ● Model

**TSM4000 H1 P - [ ] [ ] [ ] [ ] - A1**

Shock Monitor main unit

Blank: Wall mounted  
P: Panel mounted

Current sensor  
(Example: U0110)

Option code

Blank : Standard specification  
T1 : With communication function  
(consultation required)  
A1 : Analog output 4 to 20mA  
A2 : Analog output 0 to 5V

Type

Blank : Basic  
P : Panel-mounted  
H1 : Economy  
H2 : Load following  
M1 : Contact detection  
M2 : Integral power type  
M3 : Processing tool breakage detection type  
C1 : Built-in forward/reverse sequencer

Note: Use as a set with a current sensor based on the motor capacity.

## ● Outline dimensions (Basic type)

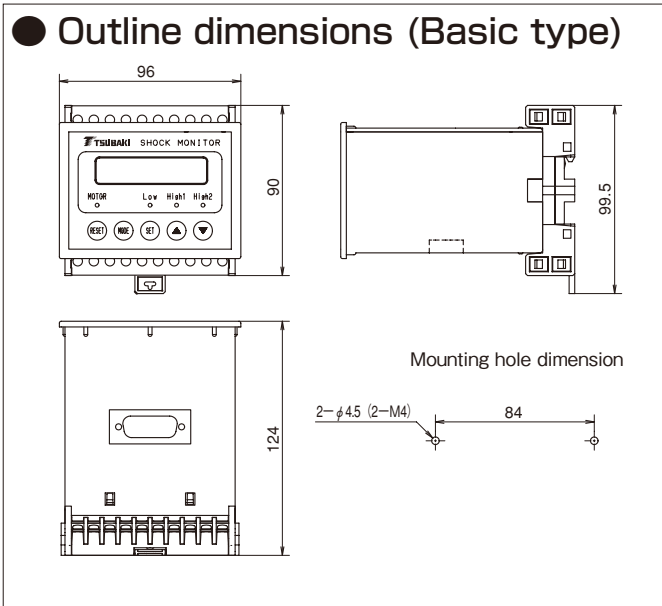

## ● Outline dimensions (Panel mounted type)

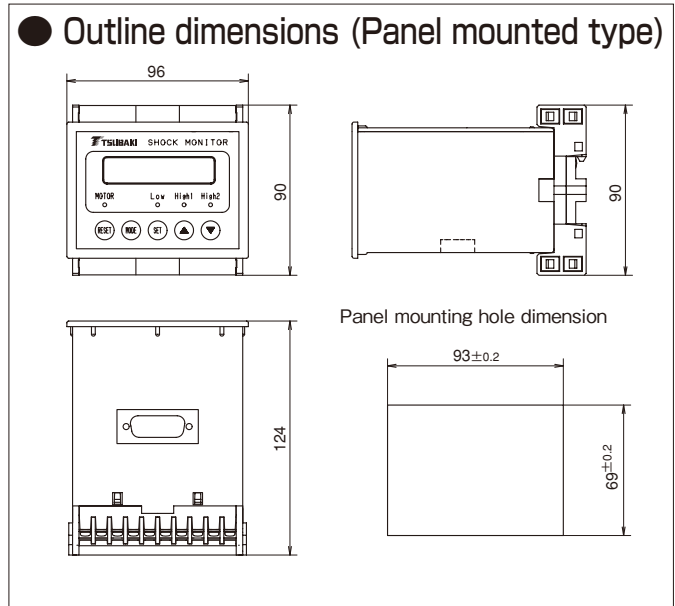

## ● Part names and functions

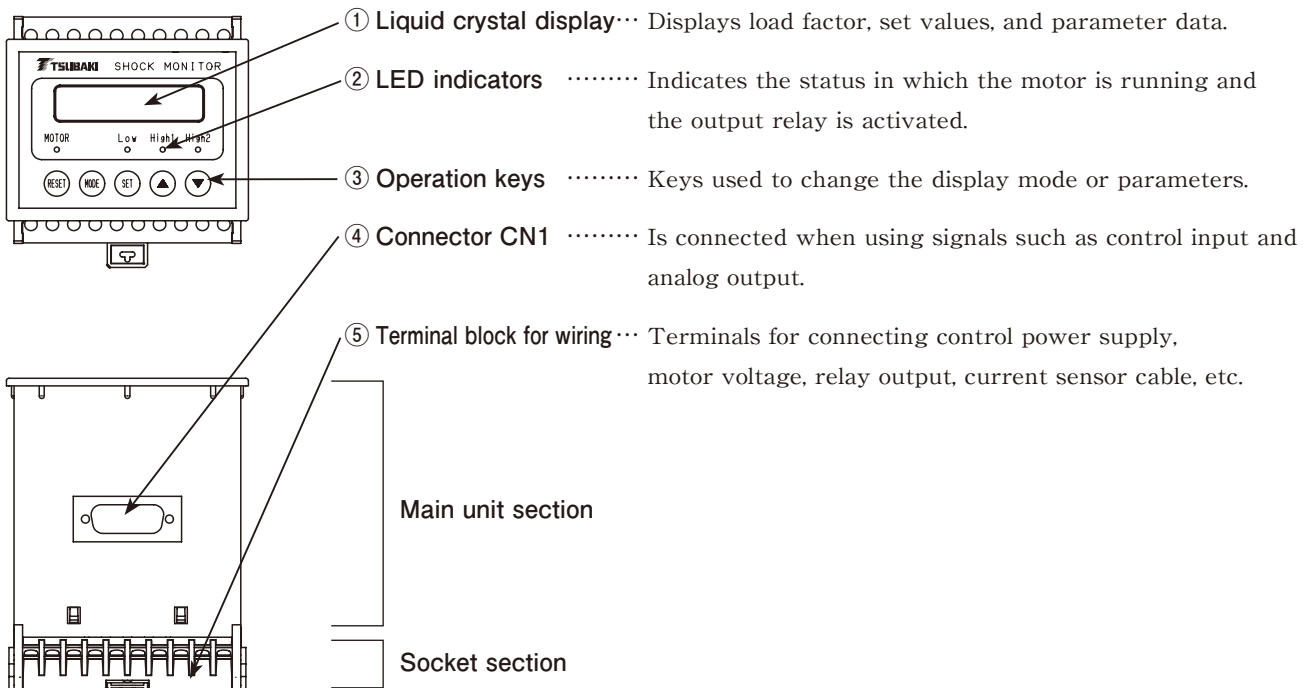

## Option

### ■ Current sensor (sold separately)

The current sensor is needed to bring motor current into the Shock Monitor unit.

Select a model from the chart below depending on the motor capacity and voltage.

Motor capacity (kW)	AC 200/220V motor		AC 400/440V motor	
	Sensor model no.	Number of wires passing through CT	Sensor model no.	Number of wires passing through CT
0.1	TSM-U010	6	TSM-U010	12
0.2	TSM-U010	3	TSM-U010	6
0.4	TSM-U010	2	TSM-U010	3
0.75	TSM-U050	6	TSM-U010	2
1.5	TSM-U050	3	TSM-U050	6
2.2	TSM-U050	2	TSM-U050	5
3.7	TSM-U050	1	TSM-U050	3
5.5	TSM-U050	1	TSM-U050	2
7.5	TSM-U100	1	TSM-U050	1
11	TSM-U100	1	TSM-U050	1
15	TSM-U150	1	TSM-U100	1
18.5	TSM-U150	1	TSM-U100	1
22	TSM-U200	1	TSM-U100	1
30	TSM-M300	1	TSM-U150	1
37	TSM-M300	1	TSM-U150	1
45	TSM-M400	1	TSM-U200	1
55	TSM-M600	1	TSM-M300	1
75	TSM-M600	1	TSM-M300	1
90	TSM-M800	1	TSM-M400	1
110	TSM-M800	1	TSM-M400	1

### Sensor model no.

TSM-U010, TSM-U050, TSM-U100, TSM-U150, TSM-U200

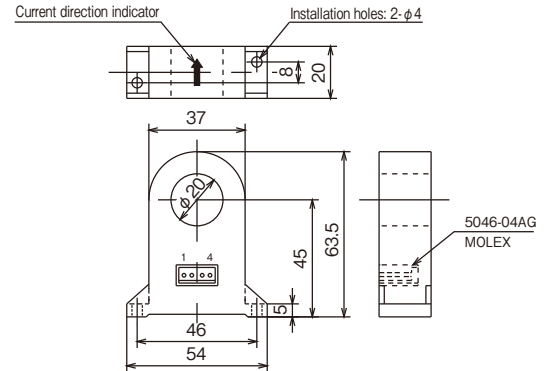

### Sensor model no.

TSM-M300, TSM-M400, TSM-M600, TSM-M800

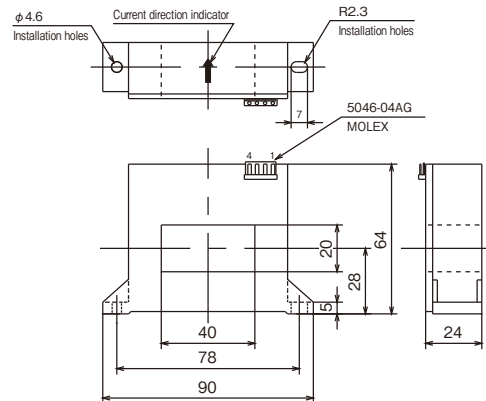

### ■ 400V class resistor

This is required if the motor voltage is 400/440V. Please order separately.

TSM4-PR1

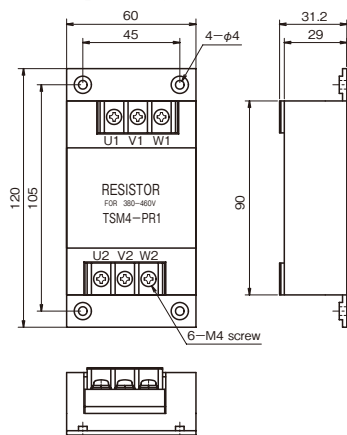

### ■ Sensor cable

A sensor cable (TSM4-S01) comes standard to connect the Shock Monitor and the current sensor. If a different cable is required, order a cable with connector as shown below.

Model No.	Cable length (L)
TSM4-S01 (attached)	1m
TSM4-S03	3m
TSM4-S05	5m
TSM4-S10	10m
TSM4-S20	20m
TSM4-S30	30m

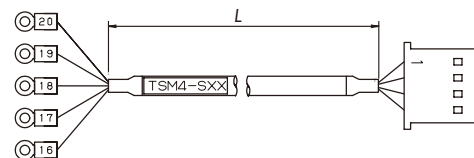

### ■ Panel mounting bracket

This bracket is used to secure the panel-mounted Shock Monitor.

TSM4-PL1

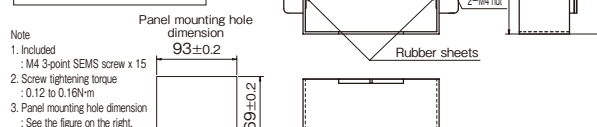

### ■ I/O cable

This cable is required when you want to perform process changeover from the outside, when resetting the Shock Monitor, and when connecting an external meter. It should be ordered as necessary.

Model No.	Cable length (L)
TSM4-C01	1m
TSM4-C03	3m

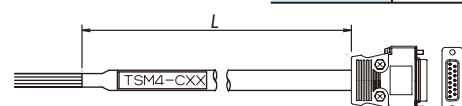

# Shock Monitor

## External connection

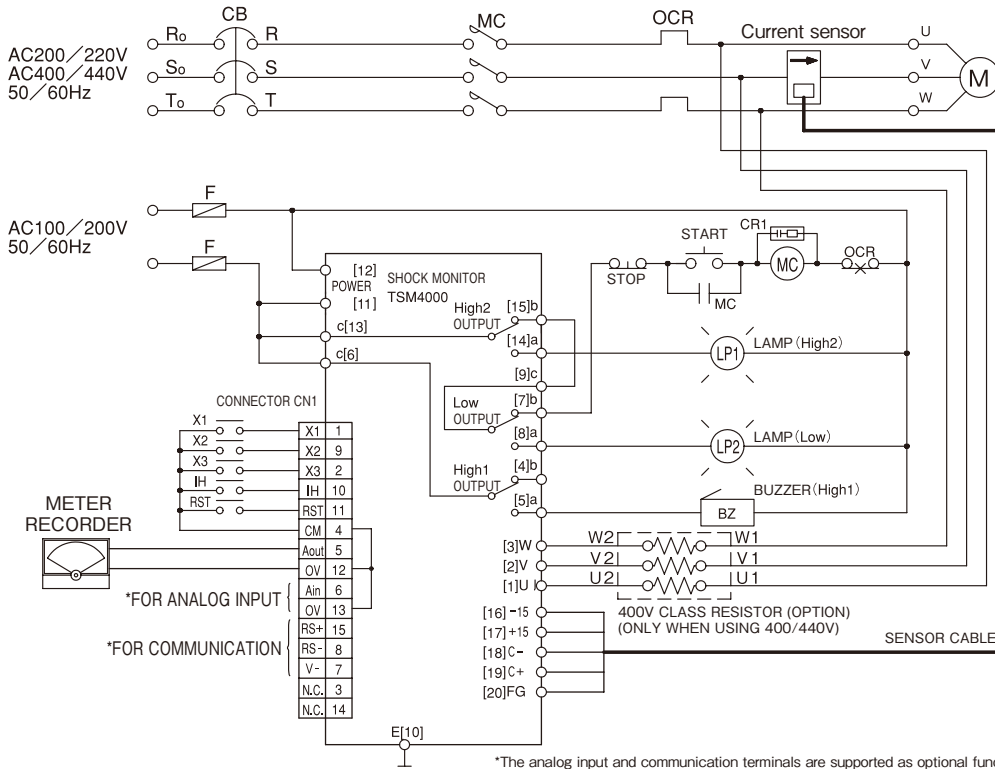

CB : Circuit breaker  
F : Fuse  
MC : Electromagnetic contactor  
for motor  
OCR : Overcurrent relay  
CR1 : CR filter  
START : Start button  
STOP : Stop button

When the operating electromagnetic coil capacity (electromagnetic capacity) of the electromagnetic contactor (MC) for the motor is less than 100 VA for injection and less than 10 VA for holding.

Note:

- Select the current sensor from the Current Sensor Table based on motor capacity and voltage. Use the specified CT through number and current direction.
  - Make sure to put the current sensor into phase V, and use the sensor cable to connect with the Shock Monitor.
  - If using a 400/440V motor, use the 400V class resistor shown in dashed line.
  - Connect the motor voltage terminal of the Shock Monitor U [1], V [2], W [3] with the phase of [U], [V], [W] respectively.
  - Use relay for minute electric current for [X1], [X2], [X3], [IH], and [RST].
- Ⓞ In case of a wrong connection, load cannot be detected correctly and the Shock Monitor will not work properly.

## Terminal functions

### Terminal block

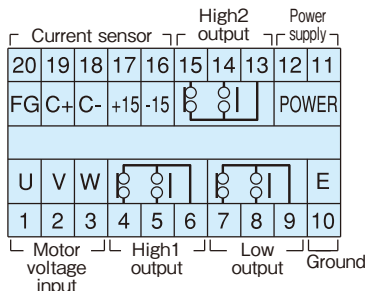

Name	Symbol	IN/OUT	Pin no.	Explanation	
Control power supply	POWER	IN	11	Connection of control power supply	
			12		
Ground	E	—	10	Ground terminal	
Current sensor			-15	Sensor cable	
			+15		17
			C-		18
			C+		19
	FG	—	20		
Motor voltage	U, V, W	IN	1	Motor voltage input terminal	
			2		
			3		
Low output	b, a, c	OUT	7	Relay contact output when lower limit output is activated	
			8		
			9		
High1 output	b, a, c	OUT	4	Relay contact output when upper limit 1 is output	
			5		
			6		
High2 output	c, a, b	OUT	13	Relay contact output when upper limit 2 is output	
			14		
			15		

### Connector CN1

X1	X3	N.C.	CM	Aout	Ain	V-	RS-
1	2	3	4	5	6	7	8
9	10	11	12	13	14	15	
X2	IH	RST	OV	OV	N.C.	RS+	

Note: Connection to pins No. 3 and 14 is prohibited.

Name	Symbol	IN/OUT	Pin no.	Explanation
Process changeover	X1, X2, X3	IN	1	Power process terminal
			9	
			2	
Inhibit	IH	IN	10	Inhibit terminal
Common	CM	IN	4	X1, X2, X3, IH, RST common terminal
Reset	RST	IN	11	Resets self-hold status

## Control input

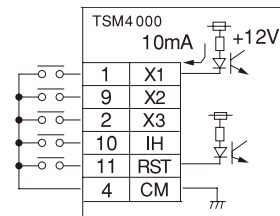

## Analog output

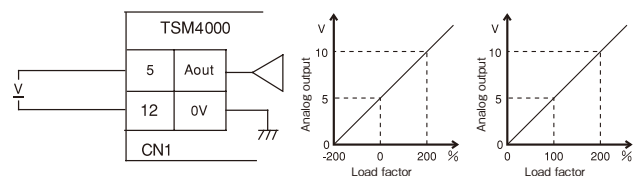

When the model supports the terminal function as standard, the analog output characteristic can be selected with Parameter 21: OUTPUT SELECT.

## Parameter settings

No.	Parameter	Data	Default settings	Details
1	Parameter Lock	(1)Unlocked (2)Locked	(1)	All parameters can be changed Parameters other than this parameter cannot be changed
2	Motor Voltage	(1)200-230V (2)380-460V	(1)	Motor voltage 3-phase 200V class Motor voltage 3-phase 400V class
3	Motor kW	0.1 to 110kW	0.75	Set motor capacity
4	Start Time	0.1 to 20.0s	3.0s	Set start time
5	Process	1 to 8	1	Number of processes
6	High2 Level Process[1]	-200 to -5% 5 to 200%	100%	Upper limit 2 value of process 1
7	Shock Time H2	MIN,0.1 to 10s	1.0s	Upper limit 2 shock time
8	Output Relay H2	(1)Self-Hold (2)Auto-Reset	(1)	Select upper limit 2 output operation mode
9	High1 Level Process[1]	-200 to -5% 5 to 200%	80%	Upper limit 1 value of process 1
10	Shock Time H1	MIN,0.1 to 10s	1.0s	Upper limit 1 shock time
11	Output Relay H1	(1)Self-Hold (2)Auto-Reset	(2)	Select upper limit 1 output operation mode
12	Low Level Process[1]	-99 to 0 to 99%	0%	Lower limit value of process 1
13	Shock Time L	MIN,0.1 to 10s	1.0s	Lower limit shock time
14	Output Relay L	(1)Self-Hold (2)Auto-Reset	(1)	Select lower limit output operation mode
15	Motor Efficiency	10 to 100%	100%	Motor efficiency
16	Response	1 to 50times	5times	Number of moving average sampling operations
17	Inhibit Time	IH,0.1 to 10s	IH	Inhibit time*
18	Auto Inhibit	(1)On (2)Off	(2)	Set auto inhibit function
19	Power/Torque	(1)Power (2)Torque	(1)	Monitor with motor input power Monitor with torque calculated by power
20	H2Relay Logic	(1)Fail Safe (2)Nomal Logic	(2)	Select fail-safe operation
21	Output Select	(1)-200 to 200% (2)0 to 200%	(2)	Select analog output
22	LCD Backlight	(1)Always (2)2min	(1)	Keep backlight on at all times Backlight turns off in 2 minutes after key operation
23	Trip Test	(1)Motor on/off (2)Motor off	(1)	Select test mode during motor operation

\* Inhibit time: Time during which power detection is temporarily stopped.

## LCD contrast adjustment

If the LCD is hard to read, hold down the SET key and press ▲ or ▼ key to adjust it.  
(Note that excessively high contrast will shorten the LCD service life.)

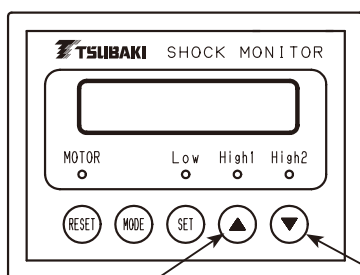

Hold down the SET key and press ▲ to make the display darker.

Hold down the SET key and press ▼ to make the display lighter.



## Applications for the Shock Monitor

Various application-specific types based on the TSM4000 basic model

Our line-up of Shock Monitors fits all kinds of applications.

### Application examples and basic operations of each type

1. Basic type: TSM4000 ..... For general industrial machines  
 Economy type: TSM4000H1 ..... For general industrial machines

The economy type has fewer functions than the basic type.

Refer to the below chart for a comparison of Shock Monitor functions.

#### ■ Damage prevention

#### ■ Preventive maintenance

### Low speed conveyor overload protection

Seats for automobiles

1/1800 reducer

Motor

Shock Monitor

Shock Monitor load factor 100%

Shock Monitor load factor 50%

Shock Monitor load factor 0%

Just pulling the conveyor by hand

These responses were detected by Shock Monitor

### Key point

There is little current variation due to a high gear ratio, making it difficult for the Shock Relay to detect the overload, so a power-detecting Shock Monitor is the best option.

### Applications

Assembly conveyor, water and sewage treatment, garbage disposal conveyors, etc.

### Bread making line lubrication maintenance

Carrying bread dough

Fermentation line

Motor

Shock Monitor

### Key point

The Shock Monitor detects a minute load rise due to a lack of lubrication on the chain. It then sends an alarm signal and operates the automatic lubricator.

### Applications

Food processing machines that operate 24 hours a day, etc.

Note: Overload may be difficult to detect depending on the characteristics of the machine. Check your usage conditions and contact us if you are considering this type of application.

### Basic operations of TSM4000H1

### ● Economical load detection is possible: Economy type

#### Simplified model with only the essential functions

Alarm output when motor power exceeds HIGH1 level.

After elapsed HIGH2 shock time, outputs the abnormal condition of the equipment.

100%

Motor power

0%

HIGH2 setting

HIGH1 setting

Setting time of Shock Monitor output after exceeding HIGH2 set value.

HIGH2 Shock time

Start time

Setting time to prevent Shock Monitor output error due to start-up power.

HIGH1 Shock time

ON HIGH2 Output relay

ON HIGH1 Output relay

#### Features

- 1) Simplified functions means easy setting.
- 2) Relay output has two outputs. It can be used as an alarm signal (HIGH1) and an abnormal level output (HIGH2).
- 3) As a set, HIGH1 and HIGH2 can be switched externally for a maximum of 4 types. It is useful for changing the setting depending on the workpiece being carried.
- 4) It comes with an efficient torque\* monitoring function (20 to 120Hz) for when using the inverter.

\*Refer to page 36, Note: \*2

#### Comparison of function: Basic model and Economy model

Function	Basic model	Economy model
Load detection	HIGH1	○
	HIGH2	○
	LOW	×
Torque monitoring function	○	○
No. of selection of detection level (No. of process to monitor)	8	4
Monitoring negative torque	○	×

## Application examples and basic operations of each type

### 2. Load following type: TSM4000H2...For general industrial machines

#### ■ Protection for efficiency-varying equipment

##### ● Equipment driven by worm reducer

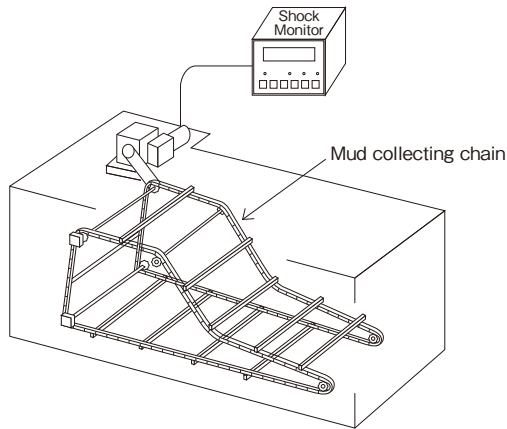

##### Key point

The efficiency of the reducer varies according to operating time. As well, even for equipment where the load factor varies, it is possible to detect abnormal condition due to the load following function.

##### Applications

Water treatment equipment, etc.

#### ■ Protection for equipment on which load periodically changes

##### ● Swivel

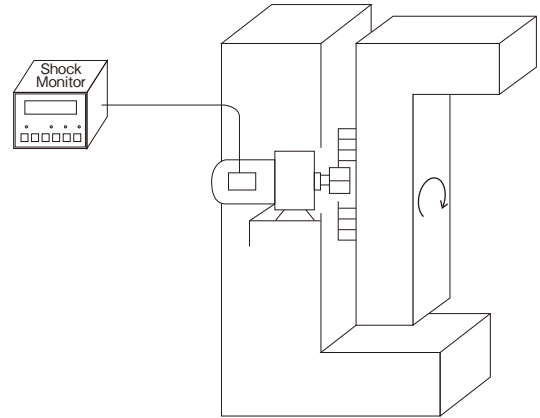

##### Key point

Even if the load of the equipment varies during 1 rotation, it is possible to detect abnormal conditions due to the load following function.

##### Applications

Medical equipment, etc.

### Basic operations of TSM4000H2

#### ● The set value automatically follows the variation in load: Load following

Because variation in machine efficiency does not affect the Shock Monitor, it makes the ideal overload protection device.

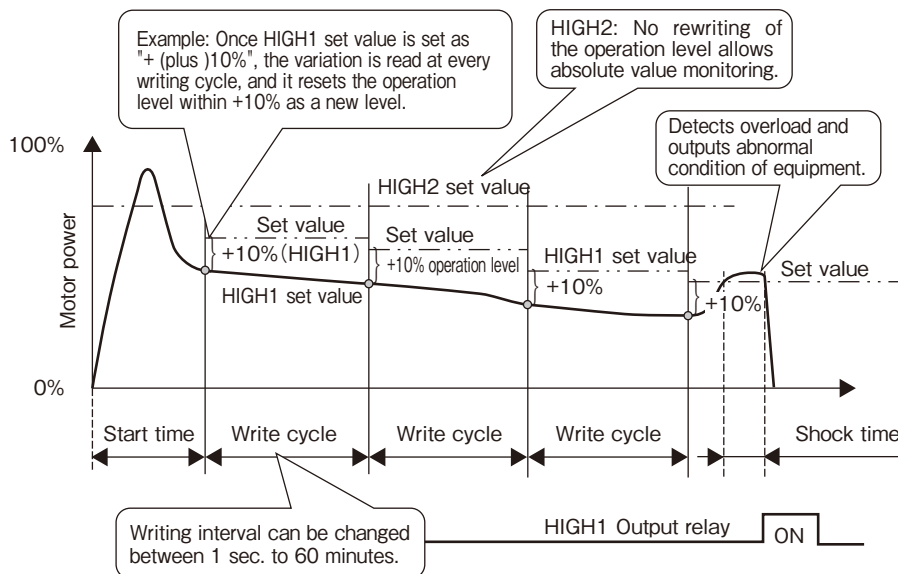

#### Features

- 1) For equipment where mechanical efficiency varies, by periodically following the operational level and minimizing the efficiency variation effect, the practical overload state can be detected.
- 2) The write cycle can be changed according to fluctuations in efficiency.
- 3) Because the operational level of HIGH2 is constant and has no variation, absolute value monitoring can be done by HIGH2.

## Application examples and basic operations of each type

### 3. Contact detection type: TSM4000M1 ····For machine tools (patent granted)

#### ■ Tool and workpiece contact detection (Feed speed control, etc.)

##### ● Grindstone contact detection

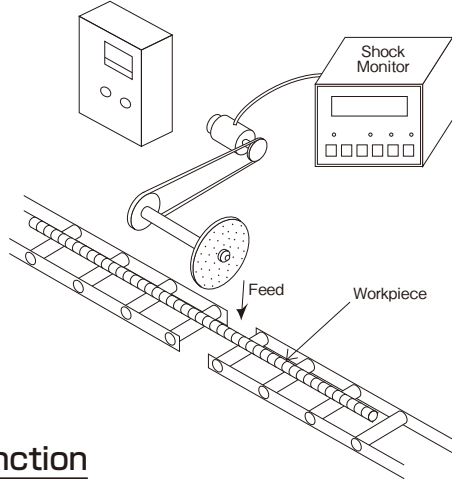

#### Function

Until the grindstone makes contact with the workpiece, the feed speed is high. After the Shock Monitor has detected contact with the workpiece, the TSM4000M1 immediately switches to a low feed speed. (Shortens work time.)

#### Key point

A minute load at the moment the grindstone contacts with the workpiece is quickly and accurately detected. Consequently, a substantial decrease in the finishing cycle time is realized.

#### Applications

Metalworking, machine tools, etc.

#### ■ Tool and workpiece contact detection

##### ● Rotational balance corrector for auto parts (crank shaft)

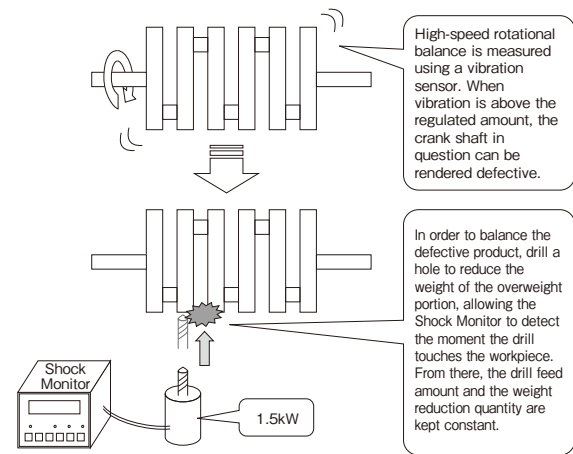

#### Function

When drilling a hole, if the drill touches the workpiece, it will be detected and the Shock Monitor will immediately output. From there, by keeping feed time constant, the drilled quantity is managed uniformly.

#### Key point

The Shock Monitor ignores common changes to idling power. Because it detects only work volume, it can securely judge the moment contact is made with the drill (0.05s).

#### Applications

Machine tools (drilling machine, grinding machine, etc.)

Note: If the power source frequency exceeds 120Hz, such as a servomotor for a machine tool's main spindle, consult Tsubaki.

### Basic operations of TSM4000M1

#### ● Rapidly detects workpiece contact: Contact detection

The idling position is automatically offset to a 0% load factor, and the Shock Monitor will detect only work volume.

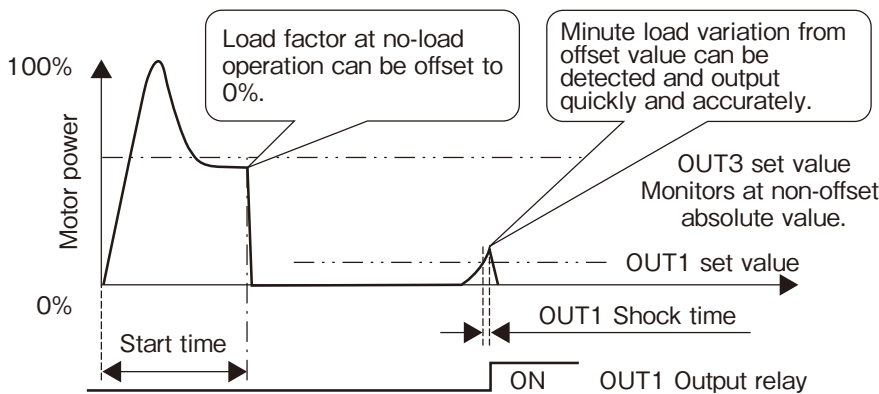

#### Features

- 1) Because the TSM4000M1 automatically offsets power during idling to 0%, the minute power change during tool and workpiece contact can be detected with high precision. (There are two types of output: OUT1 and OUT2.)
- 2) OUT3 can do absolute value monitoring with non-offset values.
- 3) In regard to detection levels, as a set, OUT1, OUT2, and OUT3 can be switched externally for a maximum of 8 types. It can deal with changes in grindstones and workpieces.

## Application examples and basic operations of each type

### 4. Integral power type: TSM400M2···· For machine tools

By integrating one cycle of power from the manufacturing process, tool wear condition and breakage, as well as overload can be detected.

#### ■ Tool service life estimation

**● Drill piece wear detection**

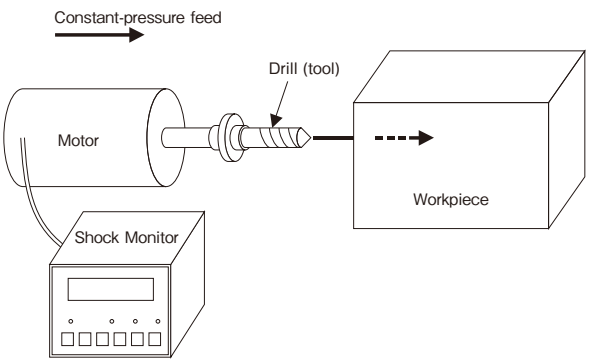

**Key point**  
In a constant-pressure finishing machine, the tool wears but the load variation is small. By taking advantage of the increase in machining time, the integral power type can precisely detect wear.

**Applications**  
Machine tools, etc.

#### ■ Check product quality

**● Screw thread quality inspection**

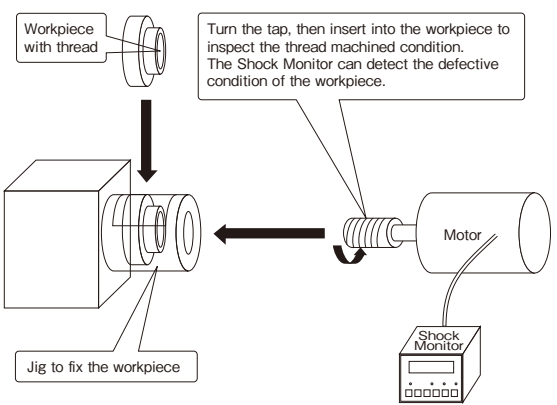

**Key point**  
Similar to checking the quality of a tap hole, the integral power type is ideal for applications where instantaneous power is unstable and setting the detection level is difficult.

**Applications**  
Inspection equipment, etc.

Note: If the power source frequency exceeds 120Hz such as a servomotor for a machine tool's main spindle, consult Tsubaki.

### Basic operations of TSM400M2

**● With total power consumption of one cycle, machine tool wear, breakage, and overload can be detected: Integral power**

Machine tool wear can be detected by integrated power, and outputting the abnormal condition.

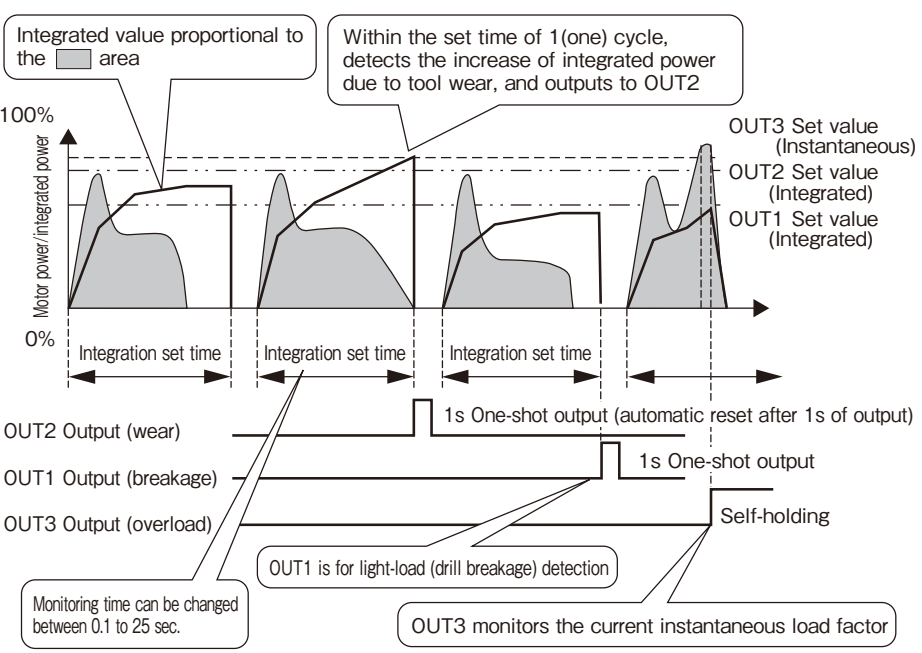

**Features**

- 1) In a constant-pressure finishing machine, the tool wears but the load factor does not increase while the machining time increases. Such an application is monitored by power consumption (area).
- 2) After machining is completed, the drill wear is detected by the upper limit of power integration (OUT2), while the drill breakage can be detected by the lower limit (OUT1).
- 3) OUT3 does absolute value monitoring of overload due to jams via instantaneous value.
- 4) As a set, OUT1, OUT2, and OUT3 can be switched externally for a maximum of 8 types. It can deal with changes in tools and workpieces.
- 5) The elapsed time setting can be changed easily.

Monitoring time can be changed between 0.1 to 25 sec.

OUT1 is for light-load (drill breakage) detection

OUT3 monitors the current instantaneous load factor

## Application examples and basic operations of each type

### 5. Processing tool breakage detection type: TSM4000M3 ... For processing tools Basic operations of TSM4000M3

#### ● How breakage detection OUT1 relay works

After the sent signal is input, the Shock Monitor determines operation to be normal if power exceeds the set value due to tool processing; however, if tool breakage occurs in the previous process, the power will not exceed the set value within the shock time period following signal input, and as a result the monitor judges tool breakage to have occurred and the OUT1 relay is output.

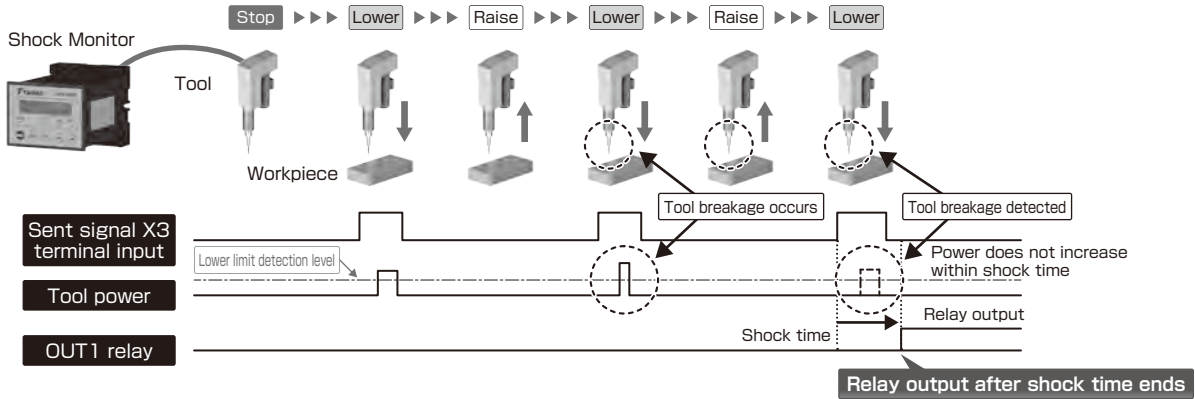

#### ● How upper limit detection OUT2 relay works

If power increases due to things like wear and overload, the upper limit is detected and the OUT2 relay is activated. When power exceeds OUT2 set value, the OUT2 relay is output after shock time ends.

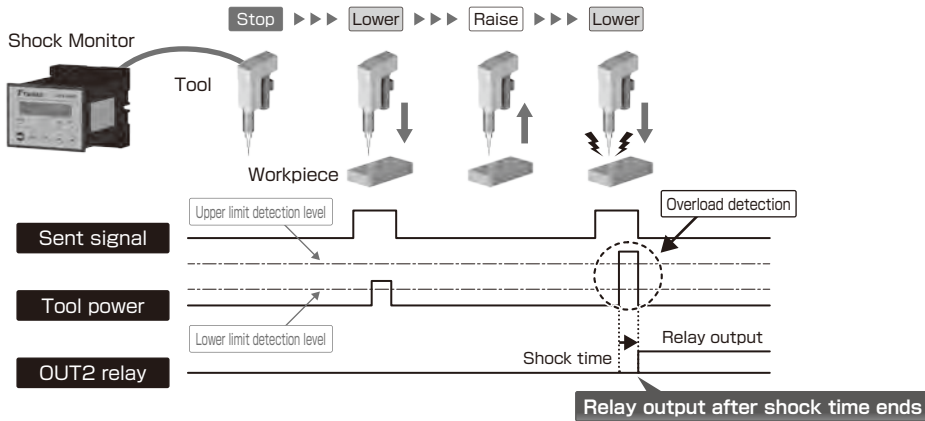

#### ● How detection of number of times of operation OUT3 relay works

After the signal sent from the tool is detected, the counter function counts up when power exceeds the OUT1 set value. When this number exceeds the pre-set number of times of operation, the OUT3 relay is output.

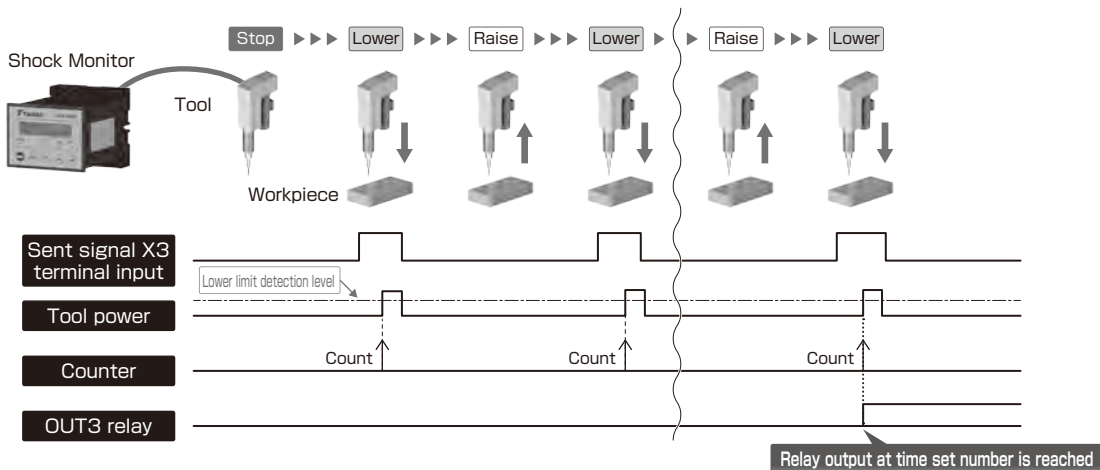

#### Precautions

This product monitors the processing motor and detects irregularities based on changes in the motor's electricity consumption. Therefore, it is not suitable for applications in which there is no change in electricity consumption between normal and irregular operation. In addition, there are cases in which this product cannot consistently detect changes of less than 5% when motor capacity is 100%. Please consult your Tsubaki dealer if the power needed for processing is small compared to motor capacity.



## Application examples and basic operations of each type

### 6. Built-in forward/reverse sequencer type: TSM4000C1.....For crushers

#### ■ Crusher blade protection and forward/reverse control

● **Crusher**

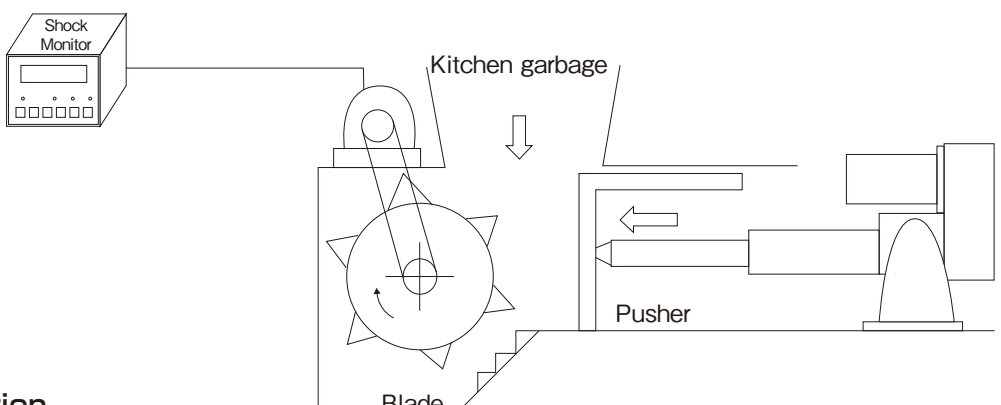

**Function**  
Precisely detects load on crusher blades. When a jam occurs, the machine automatically detects overload → the machine stops → moves into reverse → stops → moves forward repeatedly until the machine becomes un-jammed.

**Key point**  
Blade life span increases significantly. The sequence program necessary for forward and reverse movement is built-in, so it is easy to control the crusher.

**Applications**  
Crusher for waste disposal, baling press, screw conveyor, etc.

#### Basic operations of TSM4000C1

### ● When overload occurs, the machine automatically runs in reverse: Sequence program for forward and reverse rotation is built-in

#### Built-in sequence control program for crushers

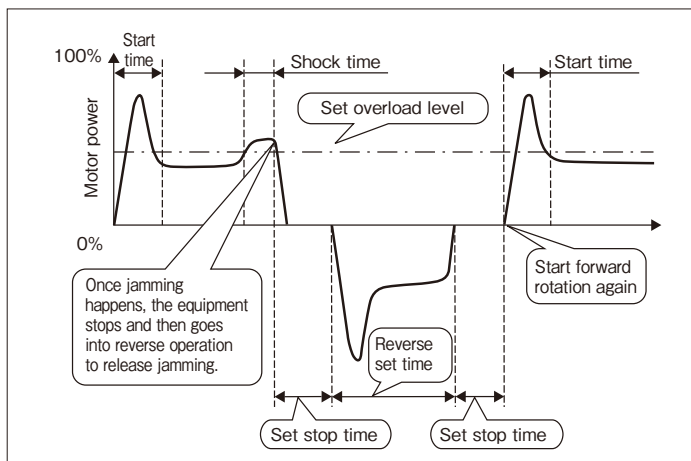
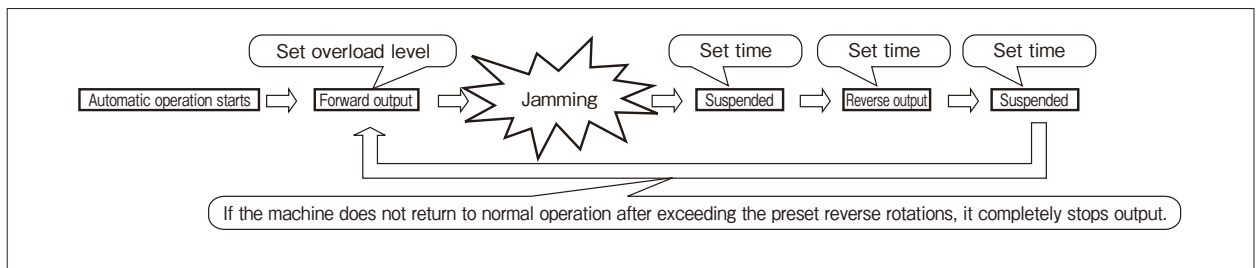

#### Features

- 1) Just by inputting the starting (forward movement) signal, stopping, reversing, and restarting during overload can be controlled without an external sequencing program.
- 2) If the preset number of reversing has past and the machine does not return to normal operation, the stop signal is output and the device can be completely stopped.
- 3) The setting of overload level, stop time, and reverse running time can be easily done on site.
- 4) To save energy, it is possible to automatically stop when there is no load.

# Shock Monitor

## External connection, parameter settings, terminal functions

### 1. Economy type TSM4000H1 ..... For general industrial machinery

#### External connection

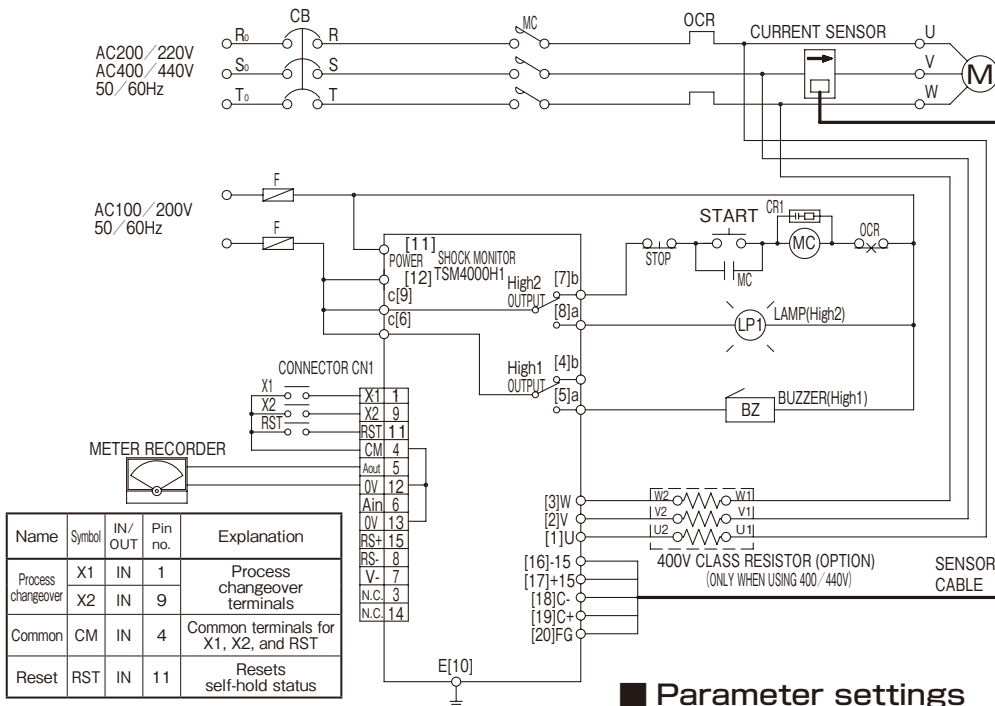

Name	Symbol	IN/OUT	Pin no.	Explanation
Process changeover	X1	IN	1	Process changeover terminals
	X2	IN	9	
Common	CM	IN	4	Common terminals for X1, X2, and RST
Reset	RST	IN	11	Resets self-hold status

CB : Circuit breaker  
 F : Fuse  
 MC : Electromagnetic contactor for motor  
 OCR : Overcurrent relay  
 CR1 : CR filter  
 START : Start button  
 STOP : Stop button

When the operating electromagnetic coil capacity (electromagnetic capacity) of the electromagnetic contactor [MC] for the motor is less than 100 VA for injection and less than 10 VA for holding.

Note:

- Select the current sensor from the Current Sensor Table based on motor capacity and voltage. Use the specified CT through number and current direction.
  - Make sure to put the current sensor into phase V, and use the sensor cable to connect with the Shock Monitor.
  - If using a 400/440V motor, use the 400V class resistor shown in dashed line.
  - Connect the motor voltage terminal of the Shock Monitor U [1], V [2], W [3] with the phase of [U], [V], [W] respectively.
  - Use relay for minute electric current for [X1], [X2], and [RST].
- ⊙ In case of a wrong connection, load cannot be detected correctly and the Shock Monitor will not work properly.

#### Terminal functions

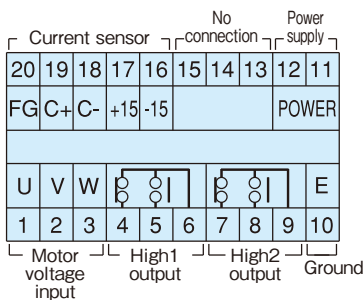

Name	Symbol	IN/OUT	Pin no.	Explanation
Control power supply	POWER	IN	11	Connection of control power supply
			12	
Ground	E	-	10	Ground terminal
Current sensor			-15	Current sensor cable
			15	
			C-	
			C+	
			FG	
Motor voltage		IN	1	Motor voltage input terminal
			2	
			3	
HIGH 1 output		OUT	4	Relay contact output when upper limit 1 is output
			5	
			6	
HIGH 2 output		OUT	7	Relay contact output when upper limit 2 is output
			8	
			9	
No connection	-		N.C	Do not connect anything
			13	
			14	
			15	

#### Parameter settings

No.	Parameter	Data	Default settings	Details
1	Motor Voltage	(1)200-230V (2)380-460V	(1)	Motor voltage 3-phase 200V class Motor voltage 3-phase 400V class
		(1)0.1kW (11)15kW (2)0.2kW (12)18.5kW (3)0.4kW (13)22kW (4)0.75kW (14)30kW (5)1.5kW (15)37kW (6)2.2kW (16)45kW (7)3.7kW (17)55kW (8)5.5kW (18)75kW (9)7.5kW (19)90kW (10)11kW (20)110kW		
2	Motor kW		0.75kW	Set motor capacity
3	Start Time	0.1 to 20.0s	3.0	Set start time
4	Process	1 to 4	1	Number of processes
5	High1 Level	5 to 200%	80	Upper limit 1 value of process 1
6	Shock Time H1	MIN 0.1 to 10.0s	1.0	Set upper limit 1 shock time
		(1)Self-Hold (2)Auto-Reset		
7	Output Relay H1		(2)	Select output operation mode (High1)
8	High2 Level	5 to 200%	100	Upper limit 2 value of process 1
9	Shock Time H2	MIN 0.1 to 10.0s	1.0	Set upper limit 2 shock time
		(1)Self-Hold (2)Auto-Reset		
10	Output Relay H2		(1)	Select output operation mode (High2)
11	Response	(1)QUICK (2)NORMAL (3)SLOW	(2)	Average number of movements
		(1)On (2)Off		
		(1)Power (2)Torque		
12	Auto Inhibit		(2)	Set auto inhibit function
13	Power/Torque		(1)	Monitor with motor input power Monitor with torque calculated by power
14	LCD Backlight	(1)Always (2)2min	(1)	Set backlight illumination time

# External connection, parameter settings, terminal functions

## 2. Load following type TSM4000H2..... For general industrial machinery

### External connection

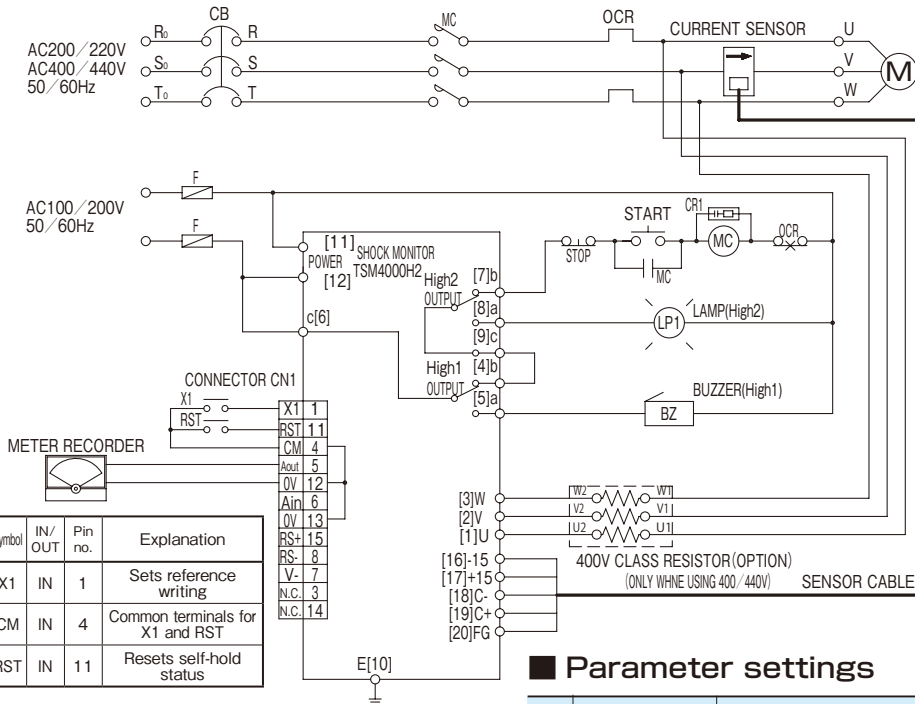

CB : Circuit breaker  
 F : Fuse  
 MC : Electromagnetic contactor for motor  
 OCR : Overcurrent relay  
 CR1 : CR filter  
 START : Start button  
 STOP : Stop button

When the operating electromagnetic coil capacity (electromagnetic capacity) of the electromagnetic contactor [MC] for the motor is less than 100 VA for injection and less than 10 VA for holding.

- Note:
- Select the current sensor from the Current Sensor Table based on motor capacity and voltage. Use the specified CT through number and current direction.
  - Make sure to put the current sensor into phase V, and use the sensor cable to connect with the Shock Monitor.
  - If using a 400/440V motor, use the 400V class resistor shown in dashed line.
  - Connect the motor voltage terminal of the Shock Monitor U [1], V [2], W [3] with the phase of [U], [V], [W] respectively.
  - Use relay for minute electric current for [X1] and [RST].
- ⊙ In case of a wrong connection, load cannot be detected correctly and the Shock Monitor will not work properly.

Name	Symbol	IN/OUT	Pin no.	Explanation
Reference writing	X1	IN	1	Sets reference writing
Common	CM	IN	4	Common terminals for X1 and RST
Reset	RST	IN	11	Resets self-hold status

### Parameter settings

No.	Parameter	Data	Default settings	Details	
1	Motor Voltage	(1)200-230V	(1)	Motor voltage 3-phase 200V class	
		(2)380-460V		Motor voltage 3-phase 400V class	
2	Motor kW	(1)0.1kW	0.75kW	Set motor capacity	
		(11)15kW			
		(2)0.2kW			(12)18.5kW
		(3)0.4kW			(13)22kW
		(4)0.75kW			(14)30kW
		(5)1.5kW			(15)37kW
		(6)2.2kW			(16)45kW
		(7)3.7kW			(17)55kW
		(8)5.5kW			(18)75kW
		(9)7.5kW			(19)90kW
(10)11kW	(20)110kW				
3	Start Time	0.1 to 20.0s	3.0	Set start time	
4	High1 Level	1 to 99%	10	Value of upper limit 1	
5	Shock Time H1	MIN	1.0	Set upper limit 1 shock time	
		0.1 to 10.0s			
6	Output Relay H1	(1)Self-Hold	(2)	Set output operation mode (High 1)	
		(2)Auto-Reset			
7	High2 Level	5 to 200%	100	Value of upper limit 2	
8	Shock Time H2	MIN	1.0	Set upper limit 2 shock time	
		0.1 to 10.0s			
9	Output Relay H2	(1)Self-Hold	(1)	Select output operation mode (High2)	
		(2)Auto-Reset			
10	Response	(1)QUICK	(2)	Average number of movements	
		(2)NORMAL			
		(3)SLOW			
11	Auto Inhibit	(1)On	(2)	Set auto inhibit function	
		(2)Off			
12	Offset Mode	(1)Interval	(2)	Set reference writing	
		(2)X1			
13	Interval Time	1 to 60s	50s	Write cycle	
		1.1 to 60.0min			
14	LCD Backlight	(1)Always	(1)	Set backlight illumination time	
		(2)2min			

### Terminal functions

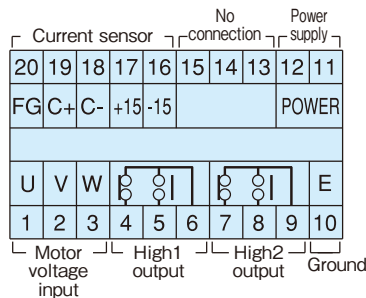

Name	Symbol	IN/OUT	Pin no.	Explanation
Control power supply	POWER	IN	11	Connection of control power supply
			12	
Ground	E	-	10	Ground terminal
Current sensor		-15	16	Current sensor cable
		15	17	
		C-	18	
		C+	19	
		FG	20	
Motor voltage		U	1	Motor voltage input terminal
		V	2	
		W	3	
HIGH 1 output		b	4	Relative value upper limit output 1
		a	5	
		c	6	
HIGH 2 output		b	7	Absolute value upper limit output 2
		a	8	
		c	9	
No connection		-	N.C 13	Do not connect anything
		-	N.C 14	
		-	N.C 15	

# Shock Monitor

## External connection, parameter settings, terminal functions

### 3. Contact detection type TSM4000M1 ..... For machine tools

#### External connection

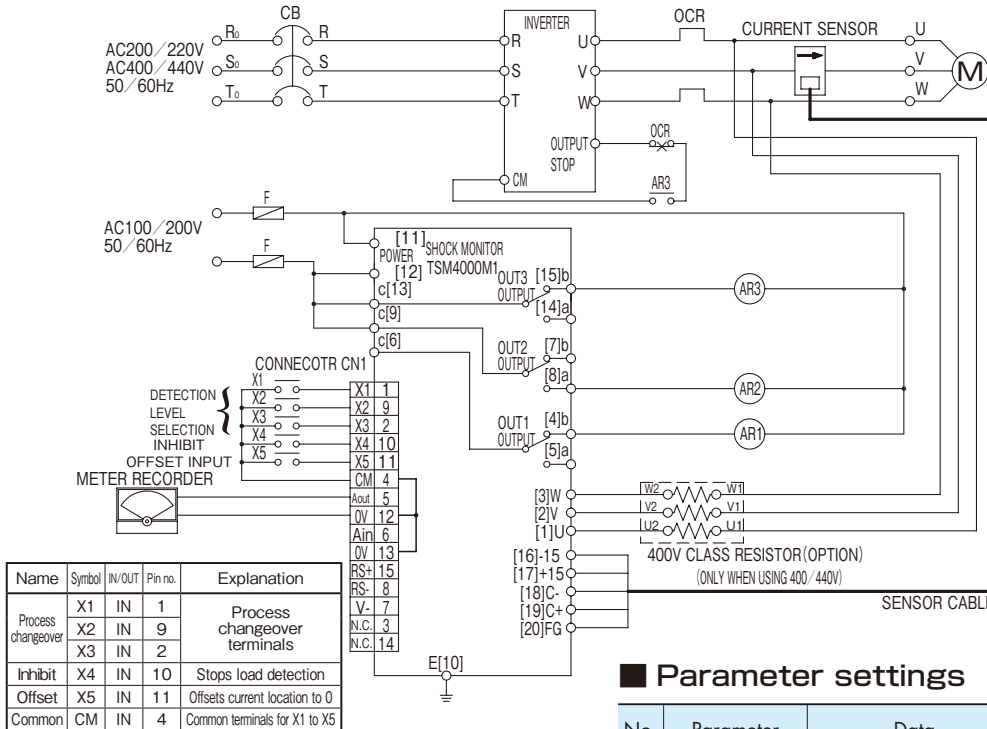

CB : Circuit breaker  
 F : Fuse  
 MC : Electromagnetic contactor for motor  
 OCR : Overcurrent relay  
 CR1 : CR filter  
 START : Start button  
 STOP : Stop button

When the operating electromagnetic coil capacity (electromagnetic capacity) of the electromagnetic contactor [MC] for the motor is less than 100 VA for injection and less than 10 VA for holding.

Note:

- Select the current sensor from the Current Sensor Table based on motor capacity and voltage. Use the specified CT through number and current direction.
  - Make sure to put the current sensor into phase V, and use the sensor cable to connect with the Shock Monitor.
  - If using a 400/440V motor, use the 400V class resistor shown in dashed line.
  - Connect the motor voltage terminal of the Shock Monitor U [1], V [2], W [3] with the phase of [U], [V], [W] respectively.
  - Use relay for minute electric current for [X1], [X2], [X3], [X4], and [X5].
- © In case of a wrong connection, load cannot be detected correctly and the Shock Monitor will not work properly.

#### Parameter settings

No.	Parameter	Data	Default settings	Details
1	Parameter Lock	(1)200-230V (2)380-460V	(1)	Parameters can be changed Parameters cannot be changed
2	Motor Voltage	(1)200-230V (2)380-460V		Motor voltage 3-phase 200V class Motor voltage 3-phase 400V class
3	Motor kW	(1)0.1kW (11)15kW (2)0.2kW (12)18.5kW (3)0.4kW (13)22kW (4)0.75kW (14)30kW (5)1.5kW (15)37kW (6)2.2kW (16)45kW (7)3.7kW (17)55kW (8)5.5kW (18)75kW (9)7.5kW (19)90kW (10)11kW (20)110kW	0.75kW	Set motor capacity
4	Start Time	0.1 to 20.0s	3.0	Set start time
5	Process	1 to 8	1	Number of processes
6	OUT1 Level	1 to 99%	10	OUT1 value
7	Shock Time OUT1	MIN 0.1 to 10.0s	1.0	OUT1 shock time
8	Output Relay OUT1	(1)Self-Hold (2)Auto-Reset	(2)	Select output operation mode (OUT1)
9	OUT2 Level	5 to 200%	15	OUT2 value
10	Shock Time OUT2	MIN 0.1 to 10.0s	1.0	OUT2 shock time
11	Output Relay OUT2	(1)Self-Hold (2)Auto-Reset	(2)	Select output operation mode (OUT2)
12	OUT3 Level	(1)QUICK	80	OUT3 value
13	Shock Time OUT3	(2)NORMAL (3)SLOW	1.0	OUT3 shock time
14	Output Relay OUT3	(1)On (2)Off	(1)	Select output operation mode (OUT3)
15	Response	(1)QUICK (2)NORMAL (3)SLOW	(2)	Average number of movements
16	Auto Inhibit	IH 0.1 to 10.0s	IH	Set inhibit time
17	Power/Torque	(1)On (2)Off	(2)	Set auto inhibit function
18	LCD Backlight	(1)Always (2)2min	(1)	Set backlight illumination time

#### Terminal functions

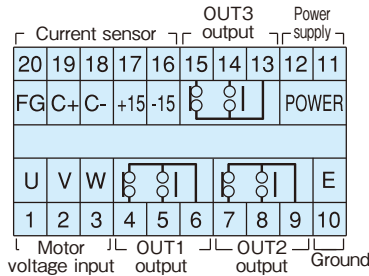

Name	Symbol	IN/OUT	Pin no.	Explanation
Control power supply	POWER	IN	11	Connection of control power supply
			12	
Ground	E	-	10	Ground terminal
Current sensor			-15	OUT 16
			15	OUT 17
			C-	IN 18
			C+	IN 19
	FG	-	20	
Motor voltage		IN	U	1
			V	2
			W	3
OUT 1 output		OUT	b	4
			a	5
			c	6
OUT 2 output		OUT	b	7
			a	8
			c	9
OUT 3 output		OUT	c	13
			a	14
			b	15

# External connection, parameter settings, terminal functions

## 4. Integral power type TSM4000M2..... For machine tools

### External connection

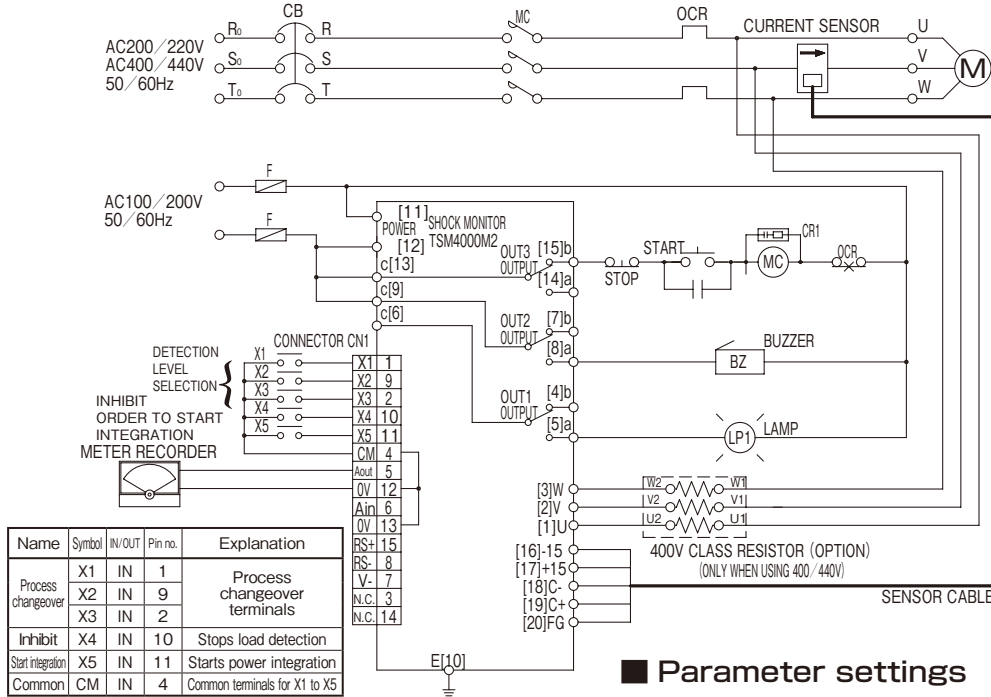

CB : Circuit breaker  
 F : Fuse  
 MC : Electromagnetic contactor for motor  
 OCR : Overcurrent relay  
 CR1 : CR filter  
 START : Start button  
 STOP : Stop button

When the operating electromagnetic coil capacity (electromagnetic capacity) of the electromagnetic contactor [MC] for the motor is less than 100 VA for injection and less than 10 VA for holding.

- Note:
- Select the current sensor from the Current Sensor Table based on motor capacity and voltage. Use the specified CT through number and current direction.
  - Make sure to put the current sensor into phase V, and use the sensor cable to connect with the Shock Monitor.
  - If using a 400/440V motor, use the 400V class resistor shown in dashed line.
  - Connect the motor voltage terminal of the Shock Monitor U [1], V [2], W [3] with the phase of [U], [V], [W] respectively.
  - Use relay for minute electric current for [X1], [X2], [X3], [X4], and [X5].
- © In case of a wrong connection, load cannot be detected correctly and the Shock Monitor will not work properly.

Name	Symbol	IN/OUT	Pin no.	Explanation
Process changeover	X1	IN	1	Process changeover terminals
	X2	IN	9	
	X3	IN	2	
Inhibit	X4	IN	10	Stops load detection
Start integration	X5	IN	11	Starts power integration
Common	CM	IN	4	Common terminals for X1 to X5

### Parameter settings

No.	Parameter	Data	Default settings	Contents		
1	Parameter Lock	(1)Unlocked	(1)	Parameters can be changed		
		(2)Locked		Parameters cannot be changed		
2	Base Time	0.1 to 25s	2.5	Set time for rated value of integrated power		
3	Integration Time	X5, 0.1 to 25s	5.0	Set time for power value integration		
4	Motor Voltage	(1)200-230V	(1)	Motor voltage 3-phase 200V class		
		(2)380-460V		Motor voltage 3-phase 400V class		
		(1)0.1kW		(11)15kW	0.75kW	Set motor capacity
		(2)0.2kW		(12)18.5kW		
		(3)0.4kW		(13)22kW		
		(4)0.75kW		(14)30kW		
		(5)1.5kW		(15)37kW		
		(6)2.2kW		(16)45kW		
		(7)3.7kW		(17)55kW		
		(8)5.5kW		(18)75kW		
(9)7.5kW	(19)90kW					
(10)11kW	(20)110kW					
6	Start Time	0.1 to 20.0s	3.0	Set start time		
7	Process	1 to 8	1	Number of processes		
8	OUT1 Level	0 to 99%	0	Value of OUT1 integrated power lower limit		
9	OUT2 Level	5 to 200%	80	Value of OUT2 integrated power upper limit		
10	OUT3 Level	5 to 200%	100	Value of OUT3 instantaneous power upper limit		
11	Shock Time OUT3	MIN	1.0	Set OUT3 shock time		
		0.1 to 10.0s				
12	Output Relay OUT3	(1)Self-Hold	(1)	Select output operation mode (OUT3)		
		(2)Auto-Reset				
13	Response	(1)QUICK	(2)	Average number of movements		
		(2)NORMAL				
		(3)SLOW				
14	Inhibit Time	IH	IH	Set inhibit time		
		0.1 to 10.0s				
15	Auto Inhibit	(1)On	(2)	Set auto inhibit function		
		(2)Off				
16	LCD Backlight	(1)Always	(1)	Set backlight illumination time		
		(2)2min				

### Terminal functions

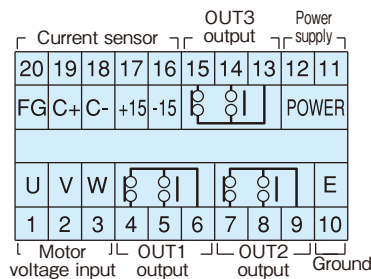

Name	Symbol	IN/OUT	Pin no.	Explanation
Control power supply	POWER	IN	11	Connection of power source
			12	
Ground	E	-	10	Ground terminal
Current sensor			-15	Current sensor cable
			15	
			C-	
			C+	
Motor voltage			U	Motor voltage input terminal
			V	
OUT 1 output			b	Lower limit output after integration
			a	
			c	
OUT 2 output			b	Upper limit output after integration
			a	
			c	
OUT 3 output			c	Upper limit output at instantaneous electric power
			a	
			b	



# Shock Monitor

## External connection, parameter settings, terminal functions

### 5. Processing tool breakage detection type: TSM4000M3.....For processing tools

#### External connection

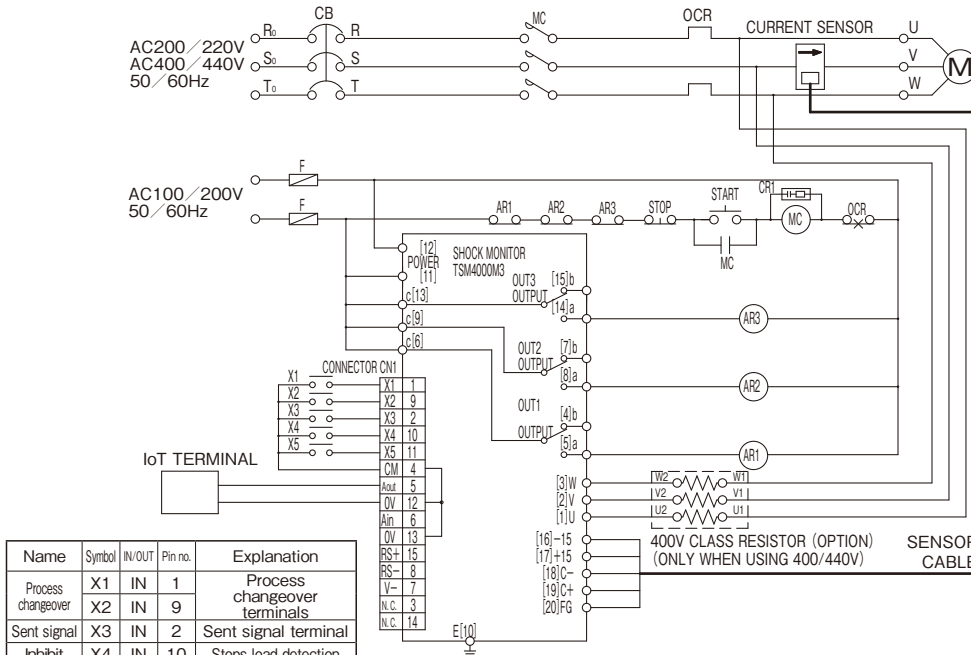

Name	Symbol	IN/OUT	Pin no.	Explanation
Process changeover	X1	IN	1	Process changeover terminals
	X2	IN	9	
Sent signal	X3	IN	2	Sent signal terminal
Inhibit	X4	IN	10	Stops load detection
Offset	X5	IN	11	Resets self-hold status
Common	CM	IN	4	Common terminals for X1 to X5

- CB : Circuit breaker
- F : Fuse
- MC : Electromagnetic contactor for motor
- OCR : Overcurrent relay
- CR1 : CR filter
- START : Start button
- STOP : Stop button

When the operating electromagnetic coil capacity (electromagnetic capacity) of the electromagnetic contactor [MC] for the motor is less than 100 VA for injection and less than 10 VA for holding.

#### Note:

- Select the current sensor from the Current Sensor Table based on motor capacity and voltage. Use the specified CT through number and current direction.
  - Make sure to put the current sensor into phase V, and use the sensor cable to connect with the Shock Monitor.
  - If using a 400V/440V motor, use the 400V class resistor shown in dashed line.
  - Connect the motor voltage terminal of the Shock Monitor U [1], V [2], W [3] respectively.
  - Use relay for minute electric current for [X1], [X2], [X3], [X4], and [X5].
- © In case of a wrong connection, load cannot be detected correctly and the Shock Monitor will not work properly.

#### Terminal functions

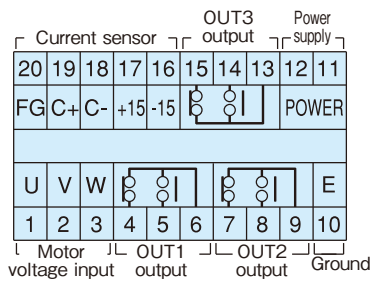

Name	Symbol	IN/OUT	Pin no.	Explanation
Control power supply	POWER	IN	11	Connection of power source
			12	
Ground	E	-	10	Ground terminal
Current sensor			-15	OUT 16
			15	OUT 17
			C-	IN 18
			C+	IN 19
			FG	- 20
Motor voltage			U	IN 1
			V	IN 2
			W	IN 3
OUT 1 output			b	OUT 4
			a	OUT 5
			c	OUT 6
OUT 2 output			b	OUT 7
			a	OUT 8
			c	OUT 9
OUT 3 output			c	OUT 13
			a	OUT 14
			b	OUT 15

#### Parameter settings

No.	Parameter	Data	Default settings	Details
1	Parameter Lock	(1)Unlocked	(1)	Parameters can be changed
		(2)Locked		Parameters cannot be changed
2	Motor Voltage	(1)200-230V	(1)	Motor voltage 3-phase 200V class Motor voltage 3-phase 400V class
		(2)380-460V		
3	Motor kW	(1)0.1kW (11)15kW	0.75kW	Set motor capacity
		(2)0.2kW (12)18.5kW		
		(3)0.4kW (13)22kW		
		(4)0.75kW (14)30kW		
		(5)1.5kW (15)37kW		
		(6)2.2kW (16)45kW		
		(7)3.7kW (17)55kW		
		(8)5.5kW (18)75kW		
		(9)7.5kW (19)90kW		
		(10)11kW (20)110kW		
4	Start Time	0.1 to 20.0s	3.0	Set start time
5	Process	1 to 4	1	Number of processes
6	OUT1 Level	0 to 99%	10	OUT1 value
7	Shock Time OUT1	MIN 0.1 to 30.0s	1.0	OUT1 shock time
8	Output Relay OUT1	(1)Self-Hold (2)Auto-Reset	(2)	Select output operation mode (OUT1)
9	OUT2 Level	5 to 200%	100	OUT2 value
10	Shock Time OUT2	MIN 0.1 to 10.0s	1.0	OUT2 shock time
11	Output Relay OUT2	(1)Self-Hold (2)Auto-Reset	(2)	Select output operation mode (OUT2)
12	OUT3 Count	100 to 30000	10000	OUT3 value
13	Output Relay OUT2	(1)Self-Hold (2)Auto-Reset	(1)	Select output operation mode (OUT3)
14	Response	1 to 50	5	Average number of movements
15	Inhibit Time	IH 0.1 to 10.0s	IH	Set inhibit time
16	Auto Inhibit	(1)On	(2)	Set auto inhibit function
		(2)Off		
17	Power/Torque	(1)Power	(1)	Monitor with motor input power Monitor with torque calculated by power
		(2)Torque		
18	LCD Backlight	(1)Always	(1)	Set backlight illumination time
		(2)2min		

# External connection, parameter settings, terminal functions

## 6. Built-in forward/reverse sequencer type TSM4000C1..... For crushers

### External connection

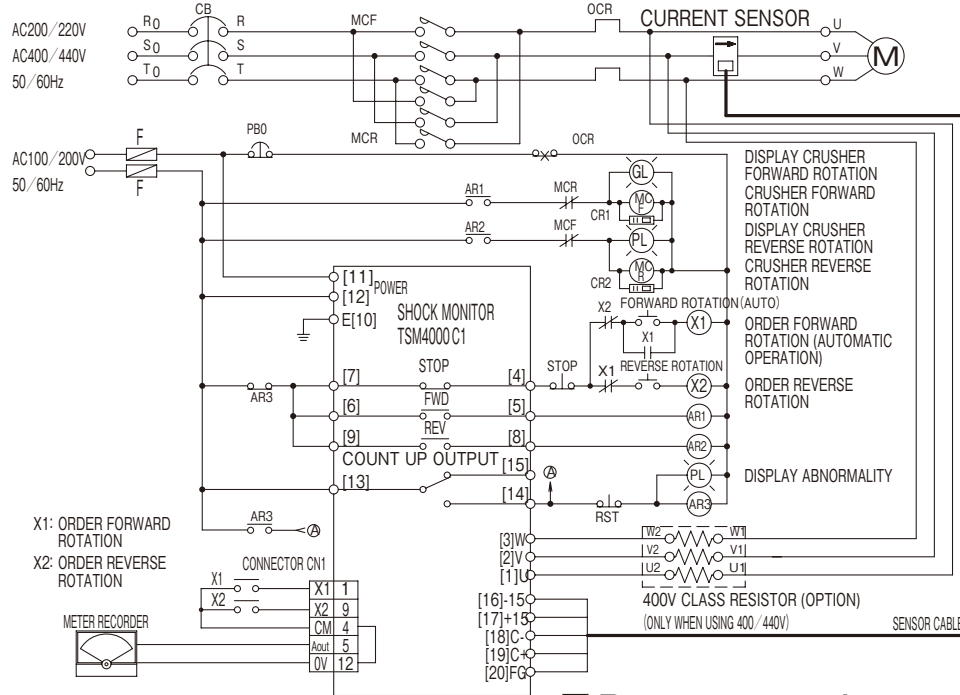

- CB : Circuit breaker
- F : Fuse
- MCF : Electromagnetic contactor for motor to forward rotation
- MCR : Electromagnetic contactor for motor to reverse rotation
- OCR : Overcurrent relay
- AR1 : Auxiliary relay for forward output
- AR2 : Auxiliary relay for reverse output
- AR3 : Auxiliary relay to light alarm lamp
- CR1, 2 : CR absorber
- PB0 : Emergency stop button
- RST : Alarm display reset

- Note:
- Select the current sensor from the Current Sensor Table based on motor capacity and voltage. Use the specified CT through number and current direction.
  - Make sure to put the current sensor into phase V, and use the sensor cable to connect with the Shock Monitor.
  - If using a 400/440V motor, use the 400V class resistor shown in dashed line.
  - Connect the motor voltage terminal of the Shock Monitor U [1], V [2], W [3] with the phase of [U], [V], [W] respectively.
  - Use relay for minute electric current for [X1] and [X2].
- © In case of a wrong connection, load cannot be detected correctly and the Shock Monitor will not work properly.

Name	Symbol	IN/OUT	Pin no.	Explanation
Auto operation input	X1	IN	1	Auto operation
Manual reverse order	X2	IN	9	Manual reverse operation
Common	CM	IN	4	Common terminals for X1 and X2

### Terminal functions

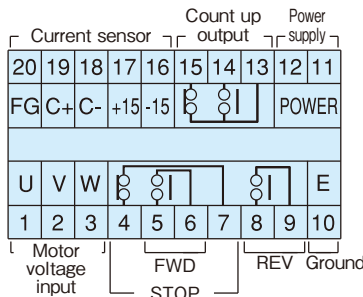

Name	Symbol	IN/OUT	Pin no.	Explanation
Control power supply	POWER	IN	11	Connection of power source
			12	
Ground	E	-	10	Ground terminal
			16	
Current sensor	-15	OUT	16	Current sensor cable
	15	OUT	17	
	C-	IN	18	
	C+	IN	19	
	FG	-	20	
Motor voltage	U	IN	1	Motor voltage input terminal
	V	IN	2	
	W	IN	3	
FWD	a	OUT	4	Order forward rotation
	c	OUT	5	
STOP	b	OUT	6	Order stop (1s shot)
	c	OUT	7	
REV	a	OUT	8	Order reverse rotation
	c	OUT	9	
Count up output	c	OUT	13	Count-up output (1s shot)
	a	OUT	14	
	b	OUT	15	

### Parameter settings

No.	Parameter	Data	Default settings	Details
1	Parameter Lock	(1)Unlock	(1)	Parameters can be changed
		(2)Lock		Parameters cannot be changed
2	Motor Voltage	(1)200-230V	(1)	Motor voltage 3-phase 200V class
		(2)380-460V		Motor voltage 3-phase 400V class
3	Motor kW	(1)0.1kW	0.75kW	Set motor capacity * Parameters (21) 132kW to (23) 200kW can be set only for a 400V class motor.
		(2)0.2kW		
		(3)0.4kW		
		(4)0.75kW		
		(5)1.5kW		
		(6)2.2kW		
		(7)3.7kW		
		(8)5.5kW		
		(9)7.5kW		
		(10)11kW		
		(11)15kW		
		(12)18.5kW		
4	No load level	Unused	Unused	Idle running prevention level
		5 to 200%		
5	Overload level	5 to 200%	100	Overload detection level
6	Start time	1 to 300s	5	Set start time
7	No load continuing level	0.1 to 60min	15.0	Time until count-up output after falling below non-load level
8	Overload duration time (Overload time)	MIN	1.0	Set shock time for when overload occurs
		0.1 to 10.0s		
9	Pause time (1)	1 to 600s	10	Pause time during switching from forward to reverse rotation
10	Reverse time	1 to 600s	5	Reverse running time
11	Pause time (2)	1 to 600s	10	Pause time during switching from reverse to forward rotation
12	No. of reverse rotation	1 to 10 times	5	No. of reverse rotations until count-up output
13	Reverse rotation	Plus	10	Time to count the no. of reverse rotations. Add to 1 cycle time
		1 to 600s		
14	Response	(1)QUICK	(2)	Average number of movements
		(2)NORMAL		
		(3)SLOW		
15	LCD Backlight	(1)Always	(1)	Set backlight illumination time
		(2)2min		



# Safety Guide and Warranty



## WARNING

Death or serious injury may result from product misuse due to not following the instructions.

- When carrying out an operation test or making a periodic inspection, make sure to verify that it functions properly as a protection device.
- Follow the instruction manual when carrying out megger testing because most electrical devices have certain requirements for megger testing.
- Check the operation of the device periodically so that it can be sure to function properly when overloaded occurs.
- Comply with the 2-1-1 General Standard of "Ordinance on Labor Safety and Hygiene".
- When performing maintenance or inspections:
  - 1) Wear proper work clothes and protective equipment (safety devices, gloves, shoes, etc.). To avoid an accident, make sure to perform maintenance and inspections in an appropriate environment.
  - 2) Make sure the power is switched off, and the machine has stopped completely before carrying out maintenance and inspections. Take the necessary measures to ensure the power is not turned back on.
  - 3) Follow the instruction manual.
  - 4) Wire according to the technical standards of Electrical Installation and company regulations. Take note of the cautions in this manual which explain installation direction, clearance and environmental conditions. Make sure to ground the device to prevent electrical shock and to improve noise resistance.
- When using with lifting equipment, install a suitable protection device for safety purposes, otherwise an accident resulting in death, serious injury or damage to the equipment may occur due to a falling accident.



## CAUTION

Minor or moderate injury, as well as damage to the product may result from product misuse due to not following the instructions.

- Consumable parts (tantalum electrolytic capacitors, relays, etc.) are built-in the products. Using the manual, periodically check the functions and operation of the device. If it is not functioning properly, contact the distributor for repair.
- Do not use the device in a corrosive gas environment. Sulphidizing gases (SO<sub>2</sub>, H<sub>2</sub>S) can especially corrode the copper and copper alloy used on PCBs and parts, and cause a malfunction.
- Read the instruction manual carefully, and use the product properly. In case the instruction manual is not available, request one from the distributor where you purchased the product, or our sales office with the product name and model number.
- Deliver this instruction manual to the final customer who uses the product.

**Warranty:** Tsubakimoto Chain Co.: hereinafter referred to as "Seller"; Customer: hereinafter referred to as "Buyer"; Goods sold or supplied by Seller to Buyer: hereinafter referred to as "Goods"

### 1. Warranty period without charge

Effective 18 months from the date of shipment or 12 months from the first use of Goods, including the installation of the Goods to the Buyer's equipment or machine - whichever comes first.

### 2. Warranty coverage

Should any damage or problem with the Goods arise within the warranty period, given that the Goods were operated and maintained according to the instructions provided in the manual, the Seller will repair and replace at no charge once the Goods are returned to the Seller.

This warranty does not include the following:

- 1) Any costs related to removal of Goods from the Buyer's equipment or machine to repair or replace parts.
- 2) Cost to transport Buyer's equipment or machines to the Buyer's repair shop.
- 3) Costs to reimburse any profit loss due to any repair or damage and consequential losses caused by the Buyer.

### 3. Warranty with charge

Seller will charge for any investigation and repair of Goods caused by:

- 1) Improper installation by failing to follow the instruction manual.
- 2) Insufficient maintenance or improper operation by the Buyer.
- 3) Incorrect installation of the Goods to other equipment or machines.
- 4) Any modifications or alterations of Goods by the Buyer.
- 5) Any repair by engineers other than the Seller or those designated by the Seller.
- 6) Operation in an environment not specified in the manual
- 7) Force Majeure or forces beyond the Seller's control such as natural disasters and injustices inflicted by a third party.
- 8) Secondary damage or problems incurred by the Buyer's equipment or machines.
- 9) Defective parts supplied or specified by the Buyer.
- 10) Incorrect wiring or parameter settings by the Buyer.
- 11) The end of life cycle of the Goods under normal usage.
- 12) Losses or damages not liable to the Seller.

### 4. Dispatch service

The service to dispatch a Seller's engineer to investigate, adjust or trial test the Seller's Goods is at the Buyer's expense.



## CAUTION

The contents of this catalog are mainly to aid in product selection. Read the instruction manual thoroughly before using the product in order to use it properly.

The logos and product names used in this catalog are either trademarks or registered trademarks of Tsubakimoto Chain Co. or the Tsubaki Group in Japan and other countries.



## TSUBAKIMOTO CHAIN CO.

Japan

Tsubakimoto Chain Co.

<https://tsubakimoto.com/>

### Global Group Companies

#### AMERICAS

United States

U.S. Tsubaki Power Transmission, LLC

<https://www.ustsubaki.com/>

Brazil

Tsubaki Brasil Equipamentos Industriais Ltda.

<https://tsubaki.ind.br/>

Canada

Tsubaki of Canada Limited

<https://tsubaki.ca/>

#### EUROPE

Netherlands

Tsubakimoto Europe B.V.

<https://tsubaki.eu/>

France

Kabelschlepp France S.A.R.L.

<https://tsubaki-kabelschlepp.com/fr-fr/>

Germany

Tsubaki Deutschland GmbH

<https://tsubaki.de/>

Tsubaki Kabelschlepp GmbH

<https://tsubaki-kabelschlepp.com/de-de/>

Italy

Kabelschlepp Italia S.R.L.

<https://tsubaki-kabelschlepp.com/it-it/>

Spain

Tsubaki Ibérica Power Transmission S.L.

<https://tsubaki.es/>

United Kingdom

Tsubakimoto UK Ltd.

<https://tsubaki.eu/>

Slovakia

Kabelschlepp-Systemtechnik, spol. s.r.o.

<https://tsubaki-kabelschlepp.com/sk-sk/>

Poland

Kabelschlepp Sp. z o.o.

<https://kabelschlepp.pl/>

#### INDIAN OCEAN RIM

Singapore

Tsubakimoto Singapore Pte. Ltd.

<https://tsubaki.sg/>

Australia

Tsubaki Australia Pty. Limited

<https://tsubaki.com.au/>

India

Tsubaki India Power Transmission Private Limited

<https://en.tsubaki.in/>

Indonesia

PT. Tsubaki Indonesia Trading

<https://tsubaki.id/>

Malaysia

Tsubaki Power Transmission (Malaysia) Sdn. Bhd.

<https://en.tsubaki.my/>

New Zealand

Tsubaki Australia Pty. Limited - New Zealand Branch

<https://tsubaki.com.au/>

Philippines

Tsubakimoto Philippines Corporation

<https://en.tsubaki.ph/>

Thailand

Tsubakimoto (Thailand) Co., Ltd.

<https://tsubaki.co.th/>

Vietnam

Tsubakimoto Vietnam Co., Ltd.

<https://tsubaki.net.vn/>

#### EAST ASIA

Republic of Korea

Tsubakimoto Korea Co., Ltd.

<https://tsubakimoto-tck.co.kr/>

Taiwan

Taiwan Tsubakimoto Trading Co., Ltd.

<https://tsubakimoto.tw/>

#### CHINA

China

Tsubakimoto Chain (Shanghai) Co., Ltd.

<https://www.tsubaki-sh.cn/>



The Tsubaki Eco Link logo is used only on products that satisfy the standards for environmental friendliness set by the Tsubaki Group.