



Tsubaki Emerson Cam Clutch couplings

- MZEU-C series -



- dimensions and capacities -

dimensions in mm.

Cam Clutch coupling model	Torque cap. N-m	Max. overrunning speed		Drag torque N-m	Clutch side stock bore size		Coupling side bore dia. range		A	B	C h7	D	E	F	G	H	I	J	L	S
		inner race rpm	outer race rpm		H7	keyway	min.	max.												
		MZEU 12-C TK	60		2,000	1,000	0.20	12												
MZEU 15-C TK	100	1,800	900	0.20	15	5x2.3	14	50	79.6	101	68	75	25	17.8	2.6	39.0	52	7.2	1	7.4
MZEU 20-C TK	245	1,600	700	0.29	20	6x2.8	14	42	85.1	109	75	63	25	17.8	3.1	44.5	57	7.2	1	7.4
MZEU 25-C TK	425	1,600	600	0.33	25	8x3.3	18	47	93.9	127	90	73	28	19.3	5.9	46.5	60	8.7	1	9.7
MZEU 30-C TK	735	1,500	500	0.39	30	8x3.3	18	47	101.9	137	100	73	28	19.3	5.9	54.5	68	8.7	1	9.7
MZEU 35-C TK	1,015	1,400	300	0.49	35	10x3.3	18	55	122.7	152	110	83	40	28.3	8.7	58.5	74	11.7	1	11.5
MZEU 40-C TK	1,350	1,400	300	0.59	40	12x3.3	20	55	132.7	164	125	83	40	28.3	6.7	68.5	86	11.7	1	11.5
MZEU 45-C TK	1,620	1,400	300	0.69	45	14x3.8	20	55	132.7	176	130	83	40	28.3	6.7	68.5	86	11.7	1	11.5
MZEU 50-C TK	2,070	1,300	250	0.79	50	14x3.8	20	55	142.2	200	150	83	40	28.3	8.2	78.0	94	11.7	1	11.5
MZEU 55-C TK	2,400	1,300	250	0.88	55	16x4.3	30	75	159.8	219	160	107	45	30.4	10.8	84.0	104	14.6	1	15.2
MZEU 60-C TK	2,950	1,200	250	0.98	60	18x4.4	30	75	170.8	235	170	107	45	30.4	11.8	95.0	114	14.6	1	15.2
MZEU 70-C TK	4,210	1,100	250	1.27	70	20x4.9	30	75	189.3	251	190	107	45	30.4	10.3	113.5	134	14.6	1	15.2
MZEU 80-C TK	5,170	800	200	1.38	80	22x5.4	30	75	196.8	267	210	107	45	30.4	7.8	121.0	144	14.6	1	15.2

- installation and usage -

1. MZEU-C series Cam Clutch couplings make use of MZEU series Cam Clutches and CR type chain couplings without cover.
2. First mount the clutch loosely on the high-speed shaft.
3. Accurately align both sprockets by checking with a straight edge on the teeth of both sprockets.
4. Check whether the clearance (S) between the two sprockets is correct, then wrap the chain around the sprockets.
5. Specify right hand (RH) or left hand (LH) inner race drive when ordering. See the drawing next.
6. The same lubrication as for Tsubaki roller chain is necessary for the coupling chain.
7. Ensure that the chain is properly closed with a connecting link and that the closed side of the spring clip is installed in the same direction as the rotation of the outer race.

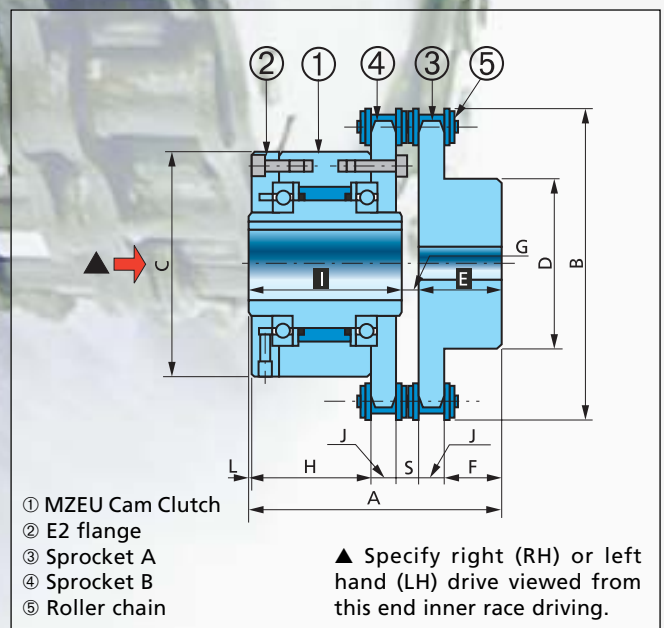

Tsubaki Emerson Cam Clutch couplings

- MZ-C & MG-C series -

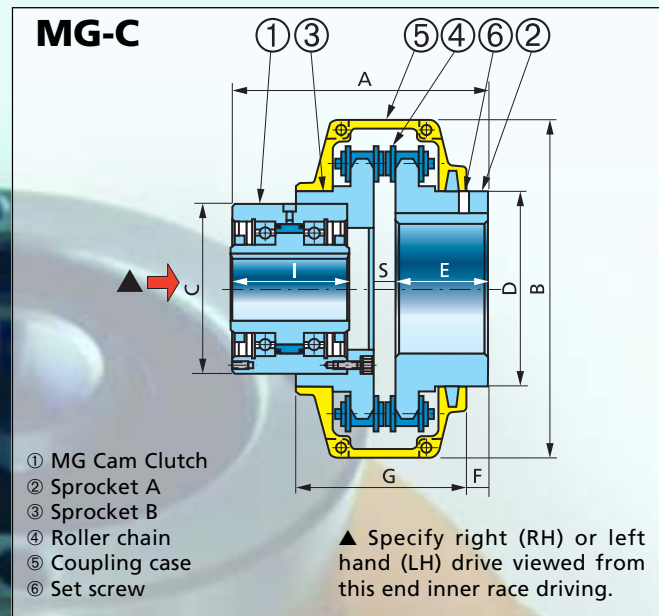
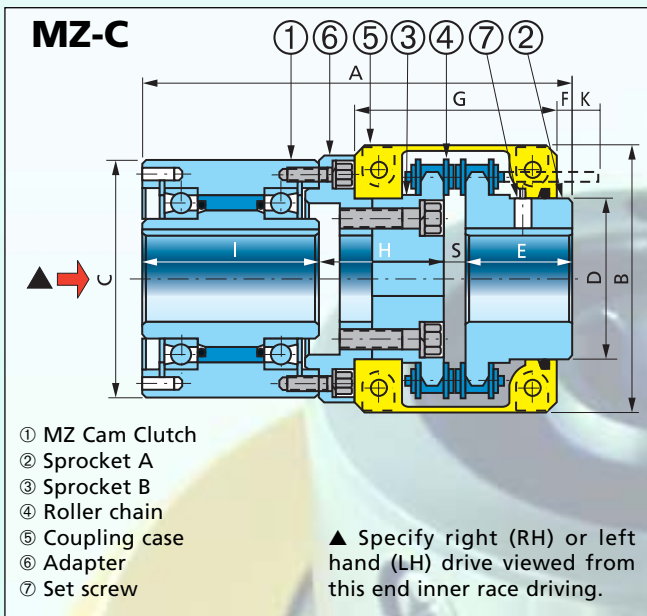

- dimensions and capacities -

dimensions in mm.

Model	Max, torque N-m	Nominal overrunning drag N-m	Max. overrunning speed r/min.		Clutch side stock bore size		Coupling side bore dia. range		A	B	C	D	E	F	G	H	I	K	S	Weight (kg)
			inner race	outer race	dia H7	keyway	min.	max.												
MZ 20C	323	0.294	1,600	700	20	6x 2.8	15	40	174	111	80	60	45	7.35	85	52.3	67	12	9.7	6.1
MZ 30C	735	0.392	1,500	500	30	10x 3.3	15	45	194	122	100	70	45	7.35	85	57.3	82	12	9.7	9.4
MZ 45C	1,620	0.686	1,400	300	45	14x 3.8	20	65	226	142	125	85	56	8.7	106	66.5	92	15	11.5	15.8
MZ 60C	2,110	0.98	1,200	250	60	18x 4.4	20	75	236	167	155	110	56	8.7	106	66.5	102	15	11.5	24.5
MZ 70C	3,040	1.27	1,100	250	70	20x 4.9	25	80	260	186	175	115	63	5.6	130	76.8	105	30	15.2	32.6
MG 300C	314	0.225	2,800	900	19	5x 2	20	56	155	142	77	85	56	8.7	106	-	11.5	-	63	8.5
MG 400C	539	0.284	2,600	800	22	5x 2	20	75	160	167	88	110	56	8.7	106	-	11.5	-	70	13.5
MG 500C	1,620	0.510	2,400	800	31.5	7x 2	30	100	195	220	108	140	71	13.55	130	-	15.2	-	89	28
MG 600C	3,140	0.843	2,100	700	50	12x 3.5	45	125	250	307	136	170	90	14.8	181	-	22.7	-	95	52
MG 700C	5,880	1.70	1,500	500	70	18x 6	55	150	275	357	180	210	100	24.8	181	-	22.7	-	127	80
MG 750C	9,510	3.43	1,800	600	85	24x 6	60	160	340	406	200	224	112	2.1	250	-	30.1	-	153	147
MG 800C	17,600	5.39	1,300	475	110	28x 7	75	200	370	472	250	280	140	30.0	250	-	30.1	-	158	182
MG 900C	24,500	6.76	1,300	400	135	35x 9	98	260	496	578	300	374	241	121.7	280	-	37.5	-	165	420
MG1000C	33,800	8.13	1,200	325	160	38x10	108	285	510	-	370	408	241	-	-	-	37.5	-	188	470

- installation and usage -

1. MZ-C series Cam Clutch couplings make use of MZ series Cam Clutches.
2. MG-C series Cam Clutch couplings make use of MG series Cam Clutches.
3. First mount the clutch loosely on the high-speed shaft.
4. Accurately align both sprockets by checking with a straight edge on the teeth of both sprockets.
5. Check if the clearance (S) between the two sprockets is correct, then wrap the chain around the sprockets.
6. Specify right hand (RH) or left hand (LH) inner race driving when ordering. See the drawing above.
7. The same lubrication as for Tsubaki roller chain is necessary for the coupling chain.

For additional advice please contact:

TSUBAKIMOTO EUROPE B.V. - Belder 1 - NL 4700 BK Roosendaal - The Netherlands
Tel. +31 (0)165 59 48 00 - Fax +31 (0)165 54 94 50 - E-mail info@tsubaki.nl - Internet www.tsubaki.nl

